

HONDA

MOTORCYCLE ELECTRICAL SYSTEMS

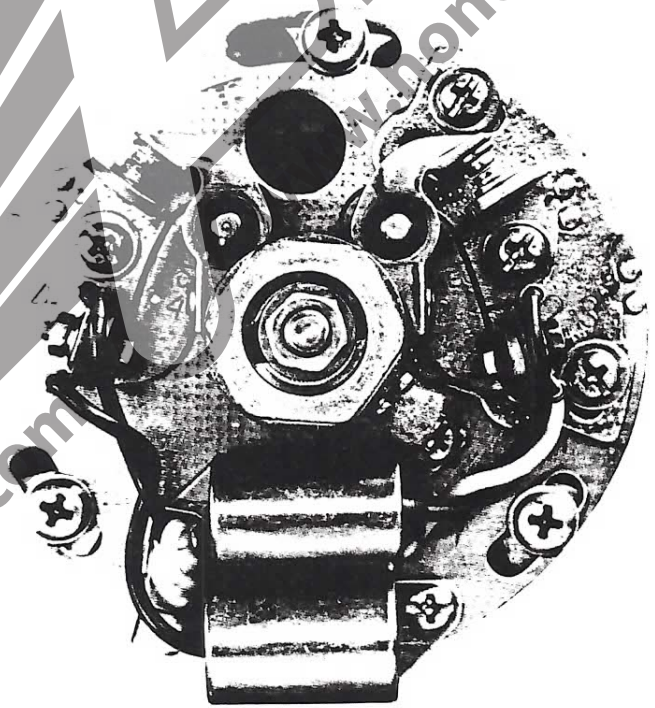

HONDA TECHNICAL SERIES

Published by AMERICAN HONDA MOTOR CO., INC.; MOTORCYCLE & POWER PRODUCTS SERVICE DEPARTMENT
EQUIPMENT AND PROCEDURES SHOWN IN THIS MANUAL APPLY TO HONDA MOTORCYCLES AVAILABLE AS OF JULY, 1977.
HONDA MOTORCYCLE MODELS FOR 1978 INTRODUCE SOME NEW OR MODIFIED EQUIPMENT AND PROCEDURES THAT ARE
NOT COVERED IN THIS MANUAL.

FOREWORD

This manual is designed to provide motorcycle owners, students, and mechanics with a complete understanding of the construction and operating principles of motorcycle electrical systems. A troubleshooting chart is included for the diagnosis and correction of electrical problems.

The manual starts with a simplified description of the basic principles. Subsequent sections describe specific electrical system circuitry, adding technical detail as the reader's comprehension grows.

Special care has been exercised in preparing clear, simple illustrations as an aid in visualizing the complex electrical systems described in the text.

The variety of electrical equipment in use, and frequent design changes, preclude the listing of service specifications. Refer to the factory shop manual for service information on specific electrical components.

Equipment and procedures shown in this manual apply to Honda motorcycles available as of July, 1977. Honda motorcycle models for 1978 introduce some new or modified equipment and procedures that are not covered in this manual.

AMERICAN HONDA MOTOR CO., INC.
MOTORCYCLE & POWER PRODUCTS SERVICE DEPARTMENT

Courtesy of
www.hondafour.com

www.honda4fun.com

TABLE OF CONTENTS

SUBJECT	PAGE
BASIC PRINCIPLES OF ELECTRICITY AND MAGNETISM	1 - 7
Electric Current	1 - 2
Series Circuit	2 - 3
Parallel Circuit	3 - 4
Current Flow	5
Magnetism	6
Magnetic Fields	6
Electromagnetism	7
A.C. GENERATORS	8 - 9
Induction	8
A.C. Generator Operation	8 - 9
RECTIFIERS	10 - 11
Half-Wave Rectifier	10 - 11
Full-Wave Rectifier	11
SOLID STATE CURRENT LIMITER	12
THREE-PHASE CHARGING SYSTEMS	12 - 15
BATTERIES	16 - 25
Battery Cell Construction	16
Battery Cell Operation	17
Specific Gravity	17 - 18
Battery Cell Voltage	19
Battery Ampere-Hour Capacity	20
Battery Identification	20 - 21
Dry-Charged Batteries	21
Preparation of New Dry-Charged Motorcycle Batteries	21 - 22
Electrolyte Level	22
Battery Vent Tube	23
Battery Cleaning	23
Battery Storage	24
Battery Charging Equipment	24
Battery Safety	25
IGNITION SYSTEMS	25 - 46
Battery Ignition	27 - 28
High Tension Magneto Ignition	29
Low Tension Magneto Ignition	30
Energy Transfer Ignition	31
Capacitor Discharge Ignition	32 - 33
Ignition Advance	33
Centrifugal Ignition Advance Operation	34
Dwell Angle and Contact Point Gap Adjustment	35
Ignition Timing Adjustment	36 - 37
Ignition Timing Marks	38

TABLE OF CONTENTS (CONTINUED)

SUBJECT	PAGE
IGNITION SYSTEMS	25 - 46
Procedure for Adjusting Contact Point Gap and Ignition Timing on Honda Single Cylinder Engines Without an Adjustable Contact Point Base Plate	38 - 39
Procedure for Adjusting Contact Point Gap and Ignition Timing on Honda Single and Twin Cylinder Engines Having One Set of Contact Points and an Adjustable Contact Point Base Plate	39
Procedure for Adjusting Contact Point Gap and Ignition Timing on Honda Twin Cylinder Engines Having Two Sets of Contact Points	40
Procedure for Adjusting Contact Point Gap and Ignition Timing on Honda Four Cylinder Air-Cooled Engines	41
Procedure for Adjusting Contact Point Gap and Ignition Timing on the Honda GL-1000	42
Spark Plugs	43 - 44
Spark Plug Heat Range	45 - 46
ELECTRIC STARTER SYSTEM	47 - 52
D.C. Motor Operating Principle	47 - 48
Starter Motor Construction	49
Starter Motor Service	50
Electromagnetic Starter Switch	51 - 52
Overrunning Clutch	52
LIGHTING SYSTEM	53 - 57
Headlights	53 - 54
Taillight and Stoplight	55
Stoplight Switches	55 - 56
Turn Signal Lights	56 - 57
HORN	57
FUEL LEVEL AND COOLANT TEMPERATURE GAUGES/COOLING FAN	58
GLOSSARY	59 - 60
ELECTRICAL SYSTEM TROUBLESHOOTING	61 - 64

Courtesy of
www.hondafour.com

HondaFun
www.honda4fun.com

HONDA MOTORCYCLE ELECTRICAL SYSTEMS

BASIC PRINCIPLES OF ELECTRICITY AND MAGNETISM

Electric Current:

A basic knowledge of electricity and magnetism is necessary for understanding the construction and operation of motorcycle electrical systems.

Electric current flowing through a wire can be compared to water flowing through a pipe. The laws governing electric circuits are easily explained by this analogy.

Water will flow through the pipe from the full tank to the empty tank (Fig. 1) until the water level is even in both tanks. Pressure (weight of water in the full tank or pressure supplied by attaching a pump) is required to cause the water to flow. A valve can be installed to open or close the water passage.

Similarly, electrical current will flow through a wire (Fig. 2) due to electrical pressure created by the battery or a generator. A switch can be installed to open or close the circuit.

Water pressure is measured in pounds per square inch, while electrical pressure is measured in *VOLTS*.

Rate of water flow, measured in gallons per minute, is analogous to rate of electrical current flow which is measured in *AMPERES*.

Water will have a lower rate of flow through a smaller or longer pipe due to increased resistance. Similarly, electric current will have a lower rate of flow through a smaller or longer wire. Partially closing the water valve in Fig. 1 decreases water flow by adding resistance, just as the resistor in Fig. 2 decreases current flow. Electrical resistance is measured in *OHMS*.

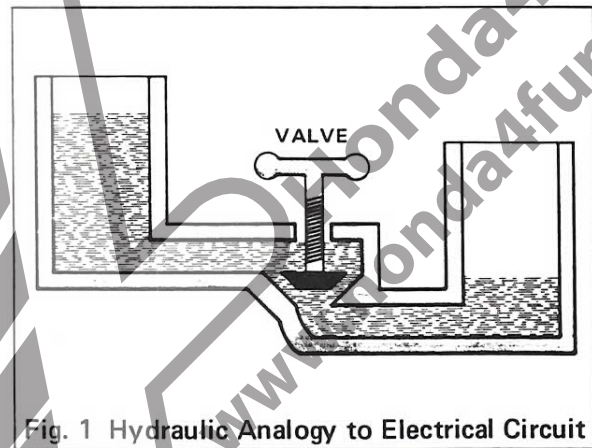

Fig. 1 Hydraulic Analogy to Electrical Circuit

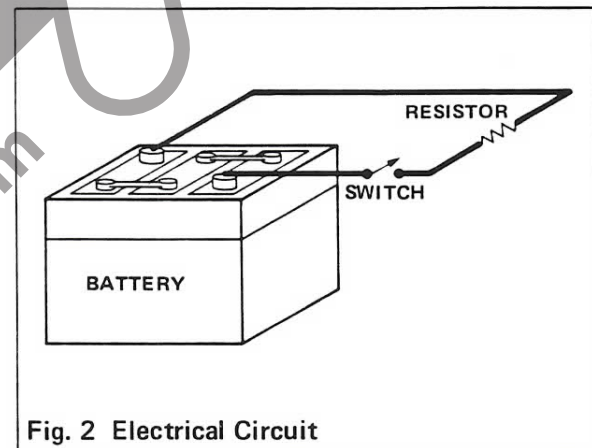

Fig. 2 Electrical Circuit

BASIC PRINCIPLES OF ELECTRICITY AND MAGNETISM

The relationship between pressure (volts), current flow (amperes), and resistance (ohms) is known as *OHM'S LAW*. Given any two values of a circuit, we can calculate the third value.

$$\begin{array}{l} \text{OHM'S} \\ \text{LAW} \end{array} \left\{ \begin{array}{l} \text{AMPERES} = \text{VOLTS} \div \text{OHMS} \\ \text{VOLTS} = \text{AMPERES} \times \text{OHMS} \\ \text{OHMS} = \text{VOLTS} \div \text{AMPERES} \end{array} \right.$$

Electrical power is measured in *WATTS*. The analogous hydraulic term would be *horsepower*. Increasing the electrical pressure (volts) or increasing the rate of current flow (amperes) increases electrical power output or consumption (watts).

$$\text{WATTS} = \text{VOLTS} \times \text{AMPERES}$$

Series Circuit:

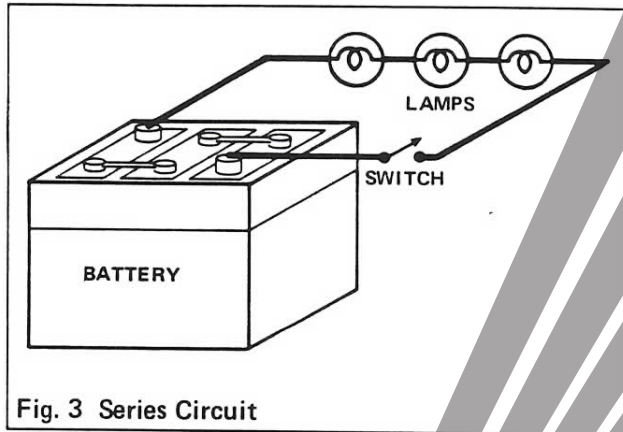

Fig. 3 Series Circuit

An electrical circuit is said to be in *series* when connected as shown in Fig. 3. Current flows through the switch and through each lamp, or other equipment, in sequence and returns from the last one to the battery. A hydraulic analogy to the series circuit is shown in Fig. 4.

In a series circuit, resistance (ohms) increases as the number of lamps or other equipment is increased. As shown by Ohm's Law, increasing the resistance (ohms) will decrease current flow (amperes) unless pressure (volts) is also increased.

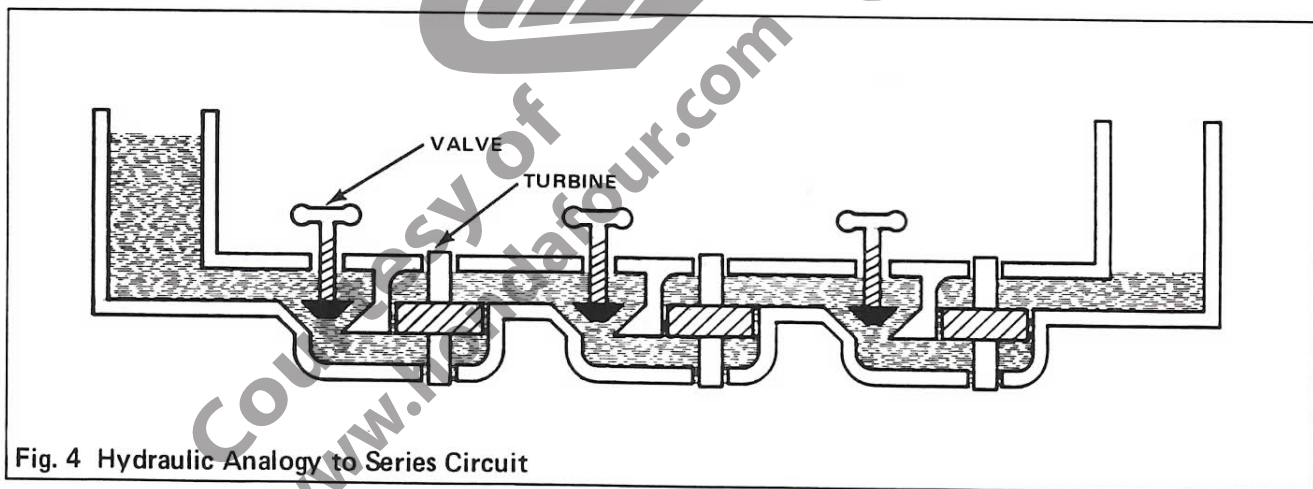

Fig. 4 Hydraulic Analogy to Series Circuit

BASIC PRINCIPLES OF ELECTRICITY AND MAGNETISM

If one lamp in a series circuit burns out, or is removed, the circuit becomes incomplete, and *all* lamps go out. The same effect can be produced in Fig. 4 by shutting down any one of the turbines. For this reason, motorcycle lighting equipment, such as headlight and taillight, are connected in parallel rather than in series.

Switches and fuses, however, must be connected in series with the equipment they control or protect. When an ammeter is used to check current flow, it too must be connected in series, so that all current in the circuit flows through the meter.

Parallel Circuit:

An electrical circuit is said to be in *parallel* when connected as shown in Fig. 5 & 6. Current flowing through any one lamp or other component will complete a circuit, returning to the battery through a common ground connection or wire. If one lamp burns out or is removed, the others will remain lit. Note that the switch is connected in *series*. When the switch is turned off, the circuit will be incomplete, and all lamps will go out simultaneously.

A considerable amount of wire can be saved by utilizing the frame and engine to complete the circuit. Ground symbols (\perp) shown in Fig. 6 indicate attachment to the frame or engine. A return wire (Fig. 5) is necessary only when the electrical components are mounted in such a manner that they are insulated from the frame and engine.

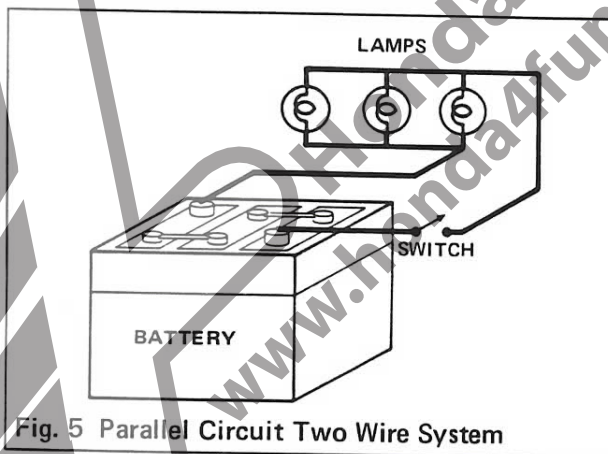

Fig. 5 Parallel Circuit Two Wire System

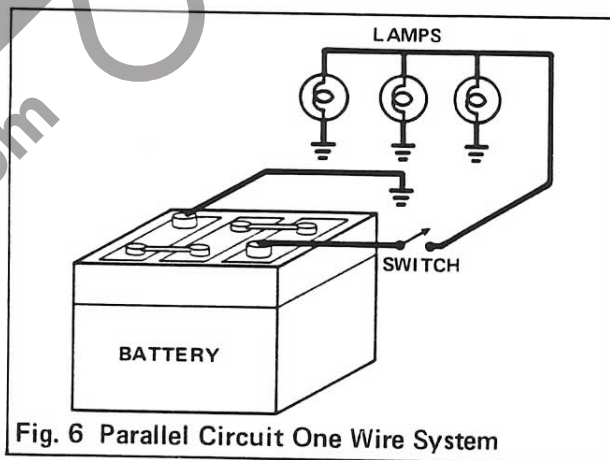

Fig. 6 Parallel Circuit One Wire System

BASIC PRINCIPLES OF ELECTRICITY AND MAGNETISM

Hydraulic analogy to the parallel circuit is shown in Fig. 7. If one turbine is shut down, the others will continue to operate and it can be clearly seen that more water will flow as more valves are opened. Opening additional passages reduces the total resistance. Similarly, as more lights are added in Fig. 5 & 6, the total resistance of the circuit (ohms) is reduced and more current (amperes) flows from the battery to operate the additional lights without requiring a voltage increase.

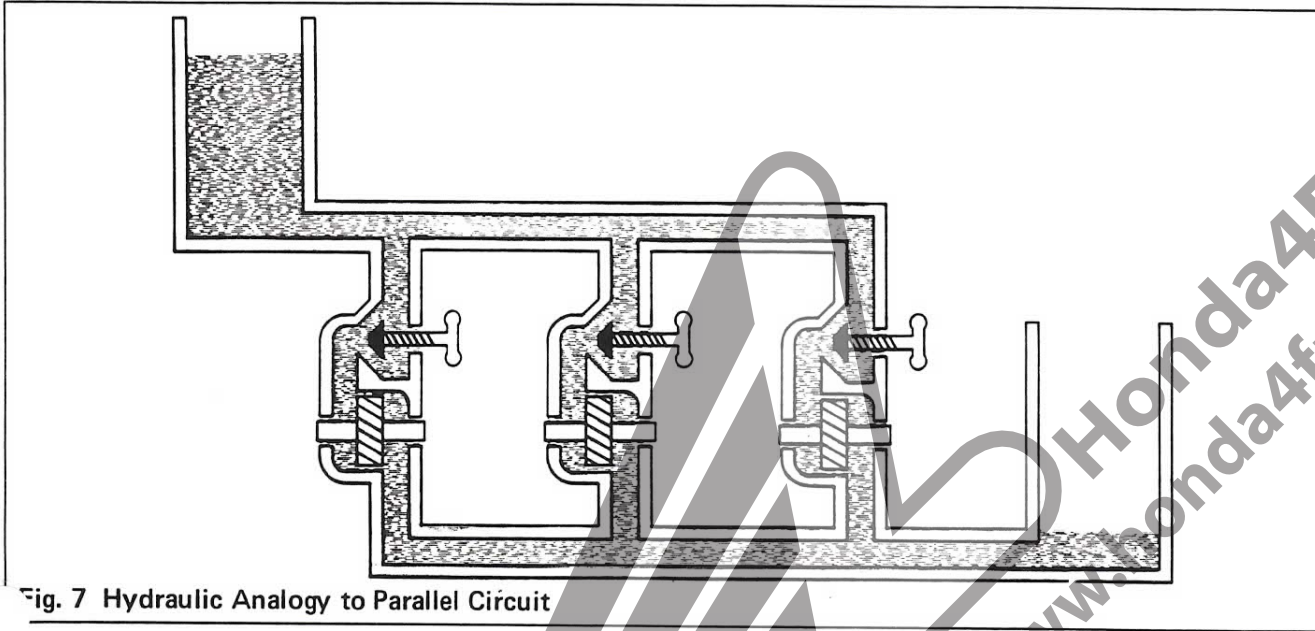

Fig. 7 Hydraulic Analogy to Parallel Circuit

The hydraulic analogy in Fig. 8 is offered as a plumber's conception of a motorcycle electrical system.

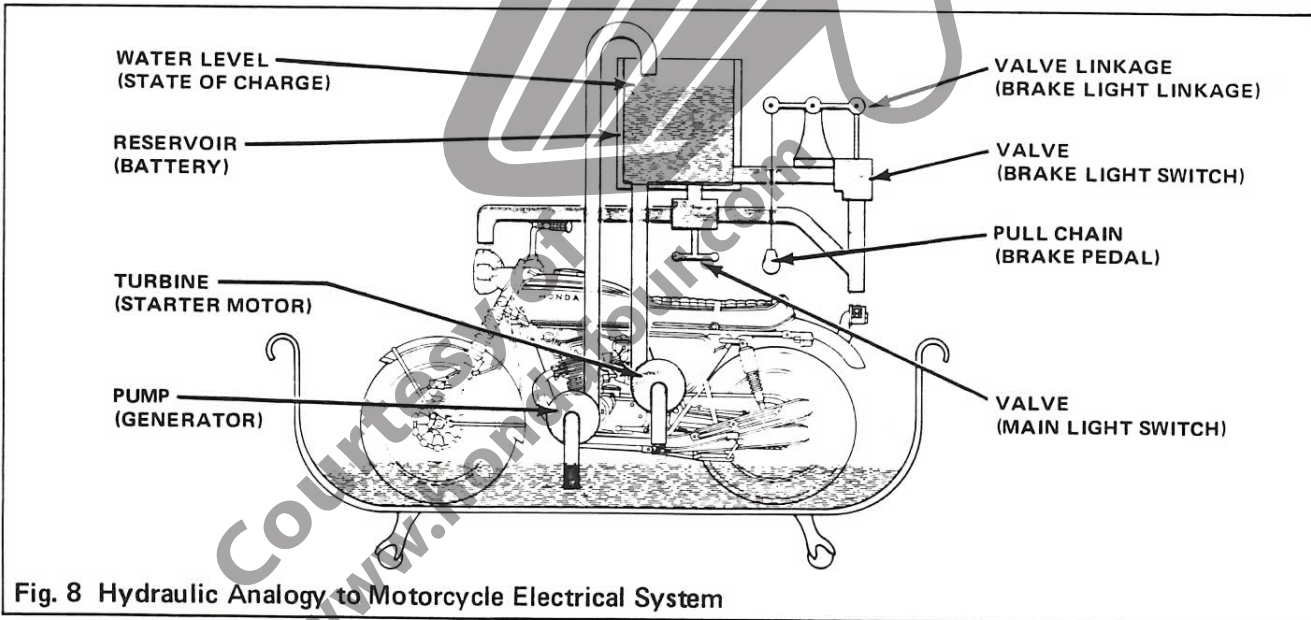

Fig. 8 Hydraulic Analogy to Motorcycle Electrical System

BASIC PRINCIPLES OF ELECTRICITY AND MAGNETISM

Current Flow.

Electric current does not really flow like water, of course. This is simply a convenient analogy for explaining electrical circuits. Electric current consists of *electrons* (the smallest possible units of negative electrical charge) moving from atom to atom within the wire.

The outer electrons are most easily freed from the atom. When voltage is applied, they will travel a short distance and collide with other atoms. The collision will knock other electrons free, and the process continues with free electrons moving by collision *toward the positive terminal* in the electrical circuit.

Copper wire is a good conductor of electricity because its atoms have a large number of easily freed electrons in their outer orbits. Insulators, such as rubber, glass, and plastics have few free electrons and are poor conductors of electricity.

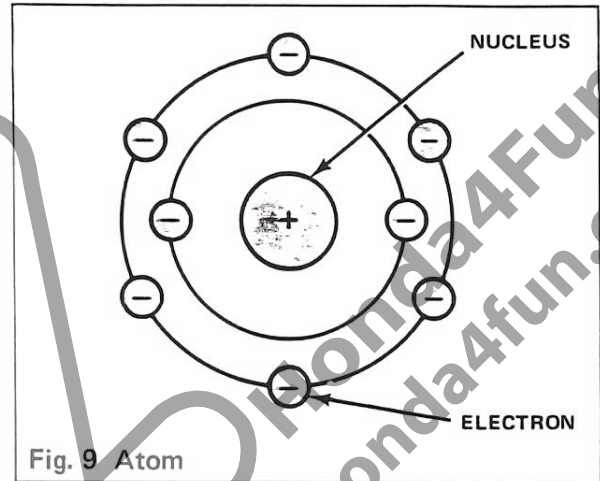

Before the nature of electricity was understood, it was thought that "electric current" flowed from the positive terminal of the voltage source, through the circuit, to the negative terminal, and all technical publications were written accordingly.

When it was discovered that electrons flowed from the negative terminal, through the circuit, to the positive terminal, it was too late to change all the books. Nor could terminals be relabeled to reconcile electron flow with old theory, as there was too much old-theory equipment in use, and relabeling terminals would cause confusion.

Thereafter, technical publications referred to "conventional current" (old theory) as flowing from positive to negative, while "electron flow" (new theory) ran from negative to positive.

With the advent of transistor technology, it became useful to consider electric current as something that flows in both directions. The electrons constitute current flowing from negative to positive, while the "holes" vacated by those electrons constitute current flowing from positive to negative.

For most purposes, the direction of current flow is of no concern, so long as you are careful to connect electrical components in proper polarity.

BASIC PRINCIPLES OF ELECTRICITY AND MAGNETISM

etism:

Magnetism is an invisible force, the nature of which has not been fully determined. The properties of magnetism are well known, however, and we are all familiar with the ability of a magnet to attract, and be attracted by, iron and magnetic alloys.

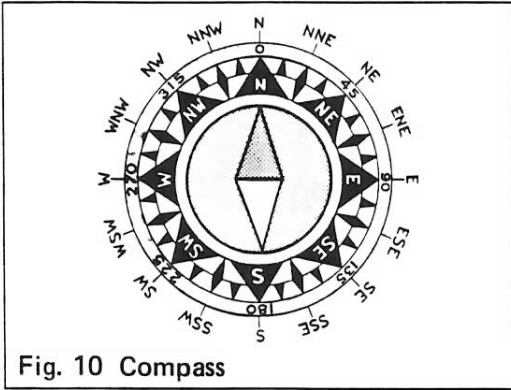

Fig. 10 Compass

Magnetic force is concentrated in the ends of the magnet, called *poles*. The poles are labeled *north* and *south* from the fact that a compass needle, which is simply a thin bar magnet, aligns itself with the north and south magnetic poles of the earth.

Think of the *north* and *south* poles of magnets as "north seeking" and "south seeking" with reference to the earth. This orientation will avoid conflict when considering that the north pole of a magnet is attracted to the "north" magnetic pole of the earth.

Unlike poles (north seeking pole of one magnet and south seeking pole of another magnet) attract each other, while like poles (two north seeking poles or two south seeking poles) repel each other. This principle, which makes a compass operate, is also used to explain the operation of such devices as electric motors and solenoids. The force of attraction or repulsion is increased when the magnets are made stronger or are brought closer together. The force is decreased when the magnets are weaker or farther apart.

Magnetic Fields:

Magnetic lines of force are considered to emanate from the north pole of the magnet, pass through the surrounding space, reenter at the south pole, and complete the circuit by passing through the magnet itself.

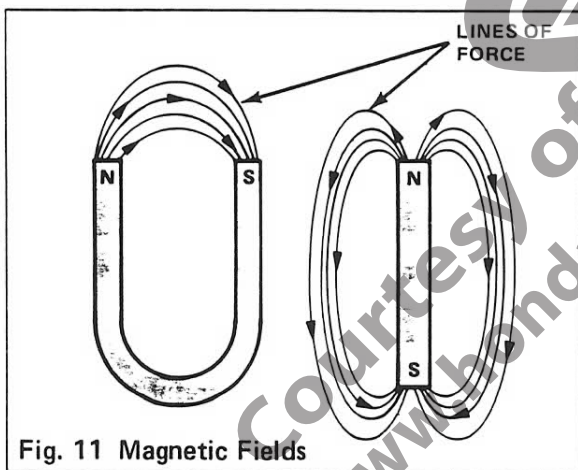

Fig. 11 Magnetic Fields

When a magnet is used to pick up iron particles, most of them will be attracted to the ends (poles) of the magnet. Magnetic force is greatest in the poles because all lines of magnetic force must pass through the poles to complete their circuits. The strength of a magnet is determined by the concentration of these lines of force.

BASIC PRINCIPLES OF ELECTRICITY AND MAGNETISM

Electromagnetism:

When an electric current flows through a wire, this sets up a magnetic field surrounding the wire. This field is regarded as magnetic lines of force encircling the wire (Fig. 12).

If the wire is wound in a coil, the magnetic lines of force form a pattern which encircles all adjoining loops of the wire (Fig. 13). This establishes a magnetic field which resembles that of a bar magnet, though many lines of force are dissipated between the loops of the coil.

When a soft iron core is inserted into the wire coil, the lines of magnetic force inside the coil will tend to travel through the iron (Fig. 14), because it provides a better magnetic path than air. This property of iron, called *permeability*, concentrates the lines of force in the center of the coil, strengthening the magnetic field. The combination of an iron core in a coil wire becomes an *electromagnet*.

When the electric current is switched off, the lines of force collapse, and the soft iron core immediately loses its induced magnetism.

A *soft iron core* is used to produce a *temporary electromagnet* in this manner, but a bar of *steel*, once magnetized, will retain its magnetism indefinitely and is called a *permanent magnet*. The magnets shown in Fig. 11 are made of steel or other magnetic alloy. Soft iron is used as the core of a temporary electromagnet.

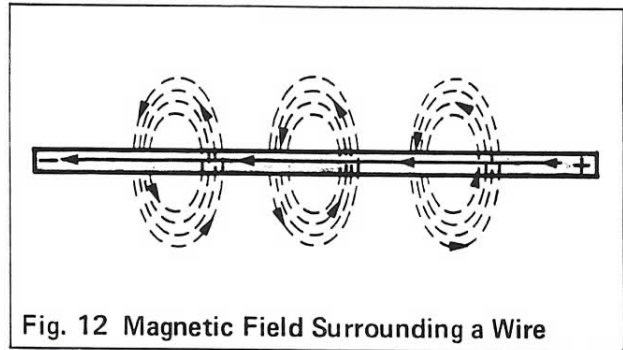

Fig. 12 Magnetic Field Surrounding a Wire

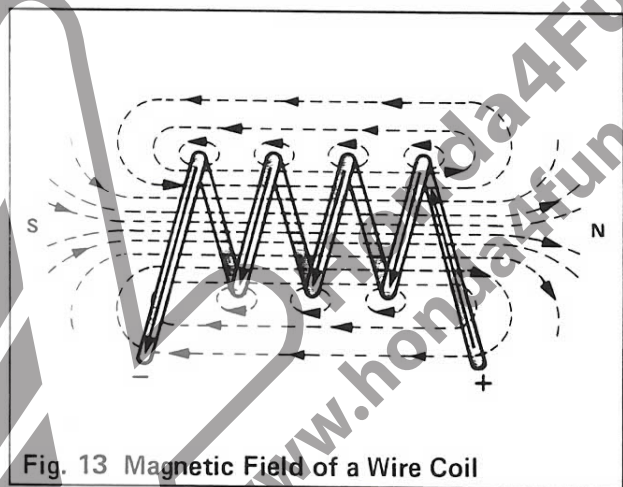

Fig. 13 Magnetic Field of a Wire Coil

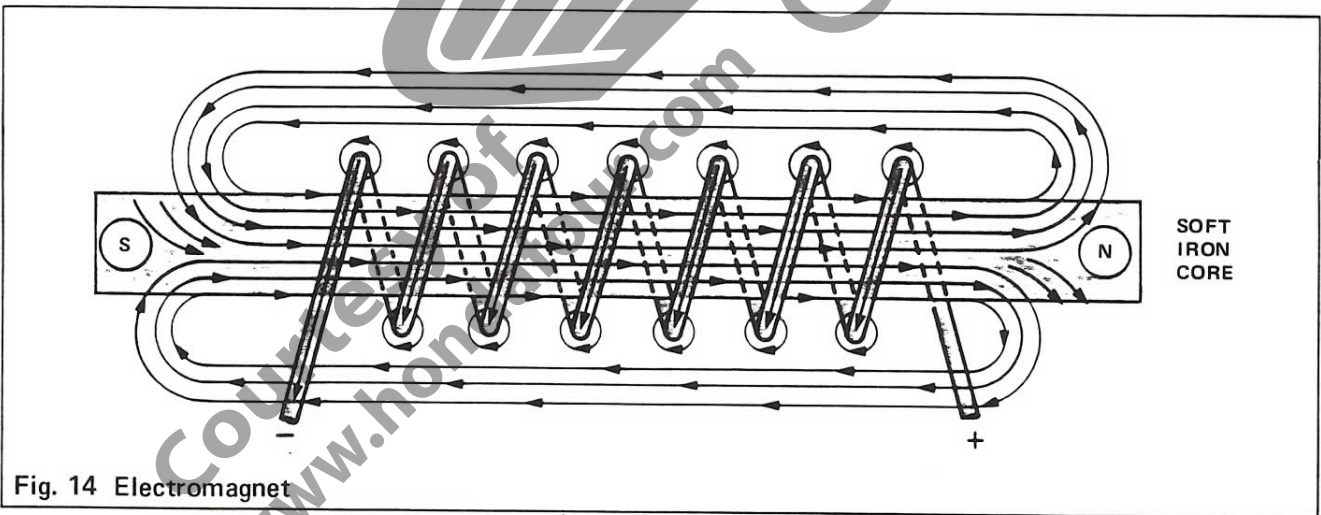

Fig. 14 Electromagnet

A.C. GENERATORS

Induction:

Induction is the process by which a magnetic field is used to create electric current. It is the operating principle of the generator.

We have seen that wherever an electric current is flowing, a magnetic field is present. Conversely, wherever there is a magnetic field, an electric current can be *induced*.

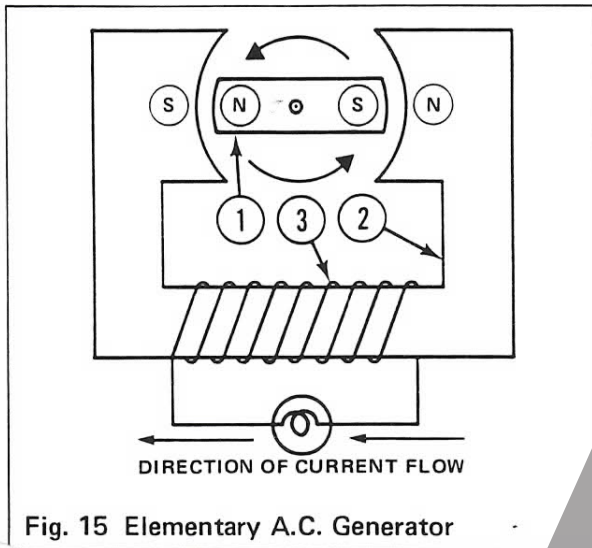

Fig. 15 Elementary A.C. Generator

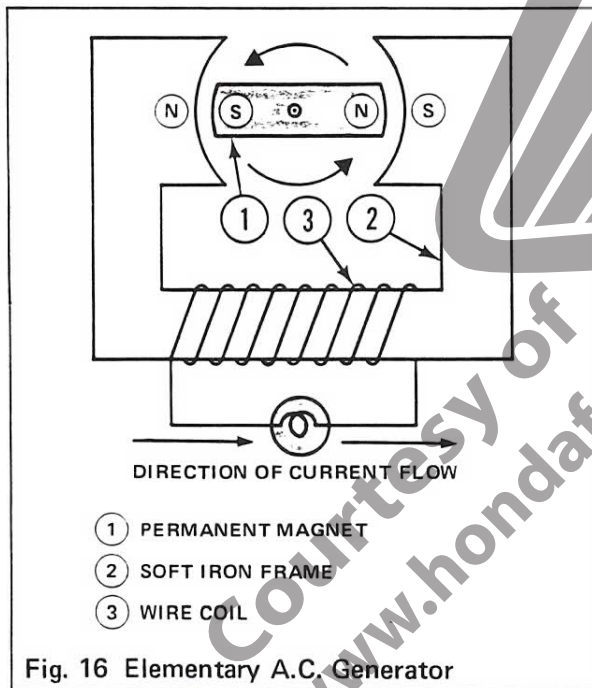

Fig. 16 Elementary A.C. Generator

An electric current is induced in a wire coil whenever lines of magnetic force are cut by the wires. The strength of the induced voltage depends on three factors:

1. The number of windings in the wire coil. The more windings there are, the more times the magnetic lines of force will be cut.
2. The strength of the magnetic field. Stronger magnets have more lines of force.
3. The speed with which the lines of magnetic force are cut by the wires.

A.C. Generator Operation:

Fig. 15 & 16 show an elementary A.C. generator. A permanent magnet ① is suspended within a soft iron frame ② which completes the circuit for the permanent magnet's lines of force. The soft iron frame thereby becomes a temporary magnet, concentrating lines of magnetic force around the wire coil ③.

When the permanent magnet ① is rotated 180° , the magnetic polarity of the soft iron frame ② is reversed. With each 180° of rotation, the magnetic lines of force around the soft iron frame collapse and then reestablish themselves in the opposite direction. Each time the lines of force collapse and rebuild, they are cut by the wire coil ③, and an electric current is induced in the wires.

The current thus generated is called "A.C." (alternating current) because the direction of current flow reverses each time the magnetic field is reversed.

The elementary A.C. generator shown in Fig. 15 & 16 has a two-pole rotating magnet and a two-pole soft iron frame. The induced current therefore reverses every 180°. A full cycle is completed every 360°.

If the motorcycle is equipped with a six-pole rotating magnet and a six-pole soft iron frame, as shown in Fig. 17, the induced current will reverse every 60°, and a full cycle will be completed every 120°. More current is generated because there are a greater number of generating coils in operation, and magnetic lines of force are cut more frequently.

An A.C. generator can be constructed with any even number of poles. It is common practice to use one set of coils to generate ignition current and another set to generate lighting current (Fig. 20), or to use one set of coils to generate the current needed for daytime operation with lights off and additional coils for nighttime operation with lights on (Fig. 17, 18, 19).

Fig. 18 illustrates the hookup for controlling the number of coils to be utilized in the generators shown in Fig. 17 & 19. Wire A carries the current produced by only one set of coils, and wire B carries the current produced by the other two sets of coils. Switch connections enable the motorcycle to be operated using A only, or A plus B.

The generator can be constructed with the rotating magnet at the center of the coil assemblies (Fig. 19) or with the coil assemblies at the center of the rotating magnet (Fig. 20). The effect is the same either way. The generator would also function if the magnet were stationary and the coil assemblies rotated, but this is not done as the coil assemblies are more susceptible to damage by centrifugal force.

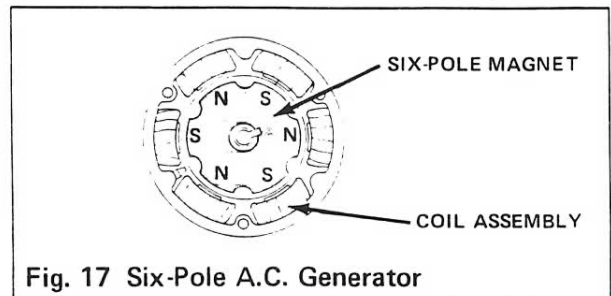

Fig. 17 Six-Pole A.C. Generator

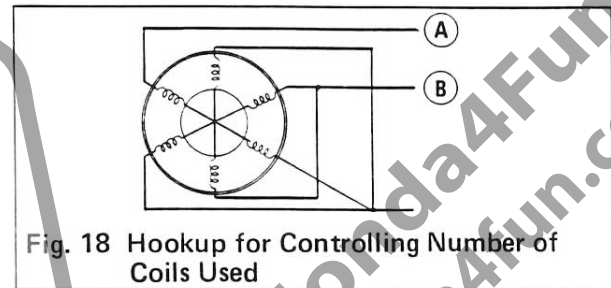

Fig. 18 Hookup for Controlling Number of Coils Used

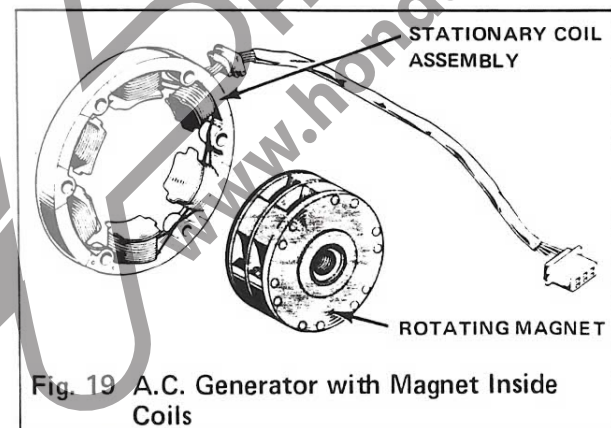

Fig. 19 A.C. Generator with Magnet Inside Coils

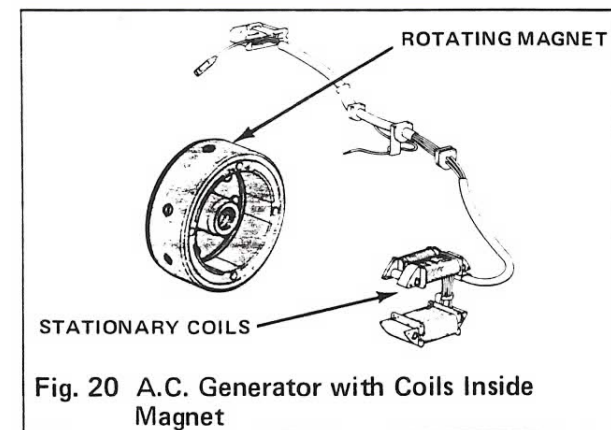
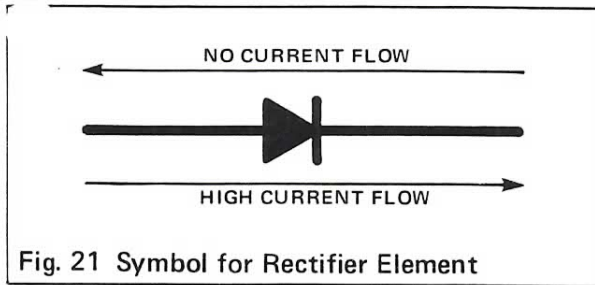
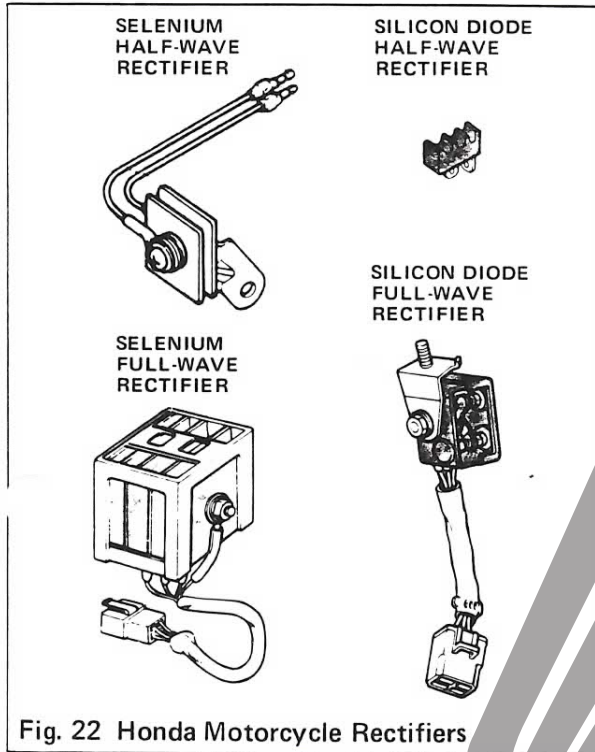

Fig. 20 A.C. Generator with Coils Inside Magnet

RECTIFIERS



A rectifier is a device for converting alternating current (A.C.) to direct current (D.C.). Because the A.C. generator produces only alternating current and the battery can only be charged by direct current, a rectifier must be installed in the circuit between the A.C. generator and battery.



Motorcycle rectifiers are constructed using selenium plates or silicon diodes which act as one-way valves, permitting current flow in one direction and resisting all current flow in the opposite direction.

The symbol used to represent a rectifier on wiring diagrams incorporates an arrow which points in the direction that *conventional current* (See Current Flow, page 5) is permitted to flow (Fig. 21).

Rectifier elements (selenium plates or silicon diodes) can be used individually as half-wave rectifiers, or grouped in bridge circuits as full-wave rectifiers.

Half-Wave Rectifier:

A.C. generator output can be illustrated as a wave form (Fig. 23) corresponding to the movement of an ammeter needle as current increases and decreases in one direction, and then increases and decreases in the opposite direction when the A.C. generator's magnetic field is reversed.

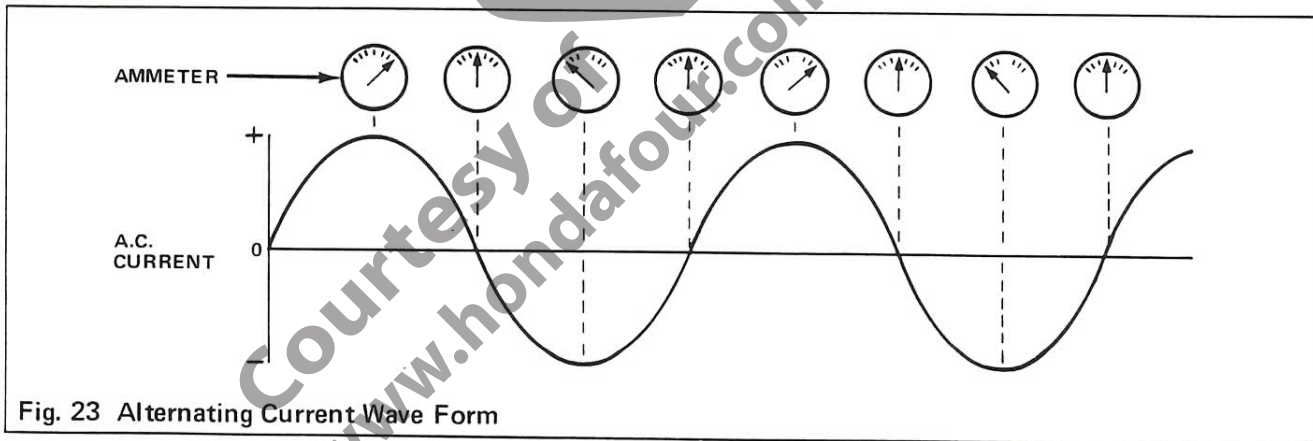

If a selenium plate or silicon diode is connected between the A.C. generator and the battery, as illustrated in Fig. 24, current flow comprising the positive half of the wave form will be passed to the battery, while negative (reverse) flow will be prevented.

A half-wave rectifier utilizes half the generator's output, but is sufficient for use on some of the smaller Honda models. A greater flow of direct current can be obtained through a full-wave rectifier which inverts the negative half of the wave form.

Full-Wave Rectifier:

The simplest full-wave rectifiers used on Honda motorcycles are made with four selenium plates or silicon diodes connected as shown in Fig. 25 (six diodes are used in rectifiers for three-phase A.C. generators). Each time the generator's alternating current reverses direction, the rectifier elements provide an alternate path to the battery. A full-wave rectifier converts the full output of the A.C. generator to direct current and passes it to the battery.

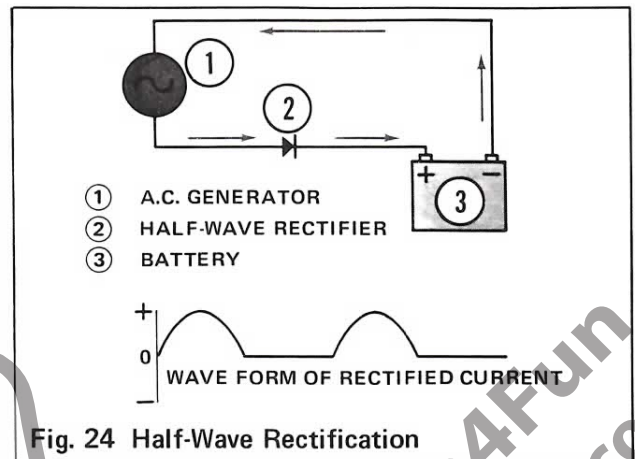

Fig. 24 Half-Wave Rectification

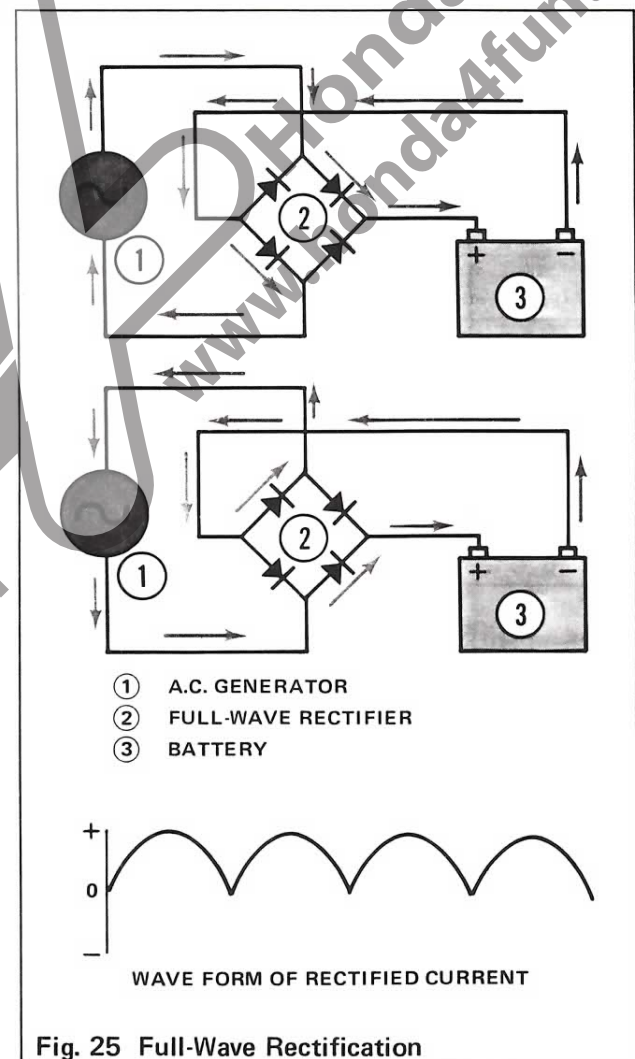

Fig. 25 Full-Wave Rectification

SOLID STATE CURRENT LIMITER/THREE-PHASE CHARGING SYSTEMS

Generator output increases with engine rpm. On models equipped with low output generators, this does not create any problem. Models equipped with higher output generators require a current limiter or voltage regulator to protect the battery from being overcharged during prolonged high rpm operation.

The solid state current limiter uses a zener diode which differs from the previously described rectifier diodes in that it does not always completely block reverse current. A reverse-biased zener diode will pass current when voltage exceeds a predetermined level, and then it passes only the amount of current exceeding that level. A solid state current limiter, containing a zener diode, is connected in the charging circuit in parallel with the battery to bleed off the excess current that would otherwise overcharge the battery at high rpm.

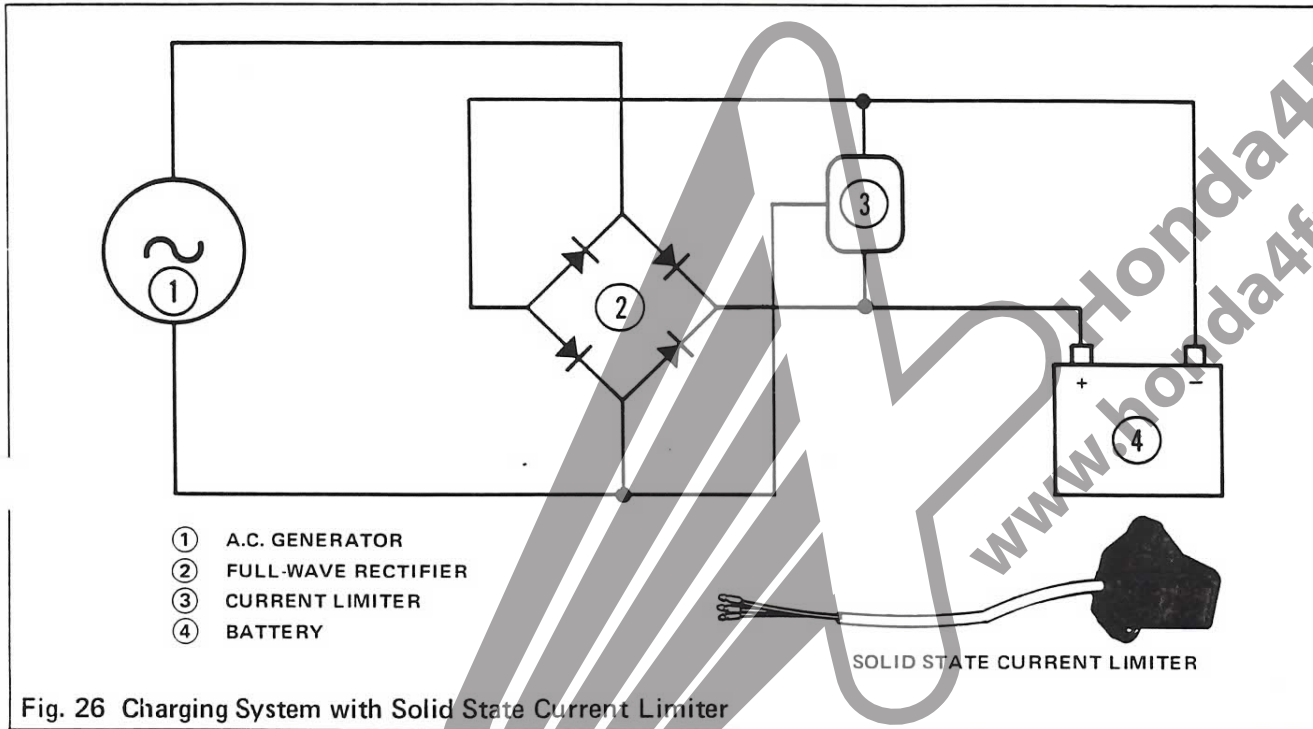
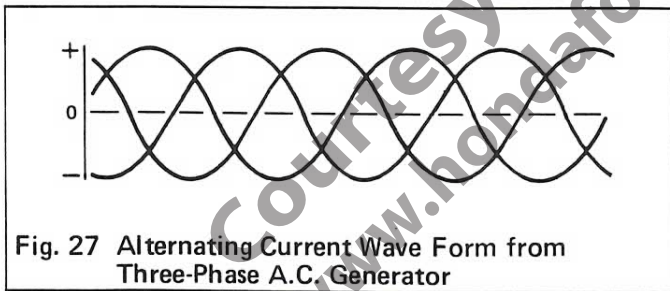

Fig. 26 Charging System with Solid State Current Limiter

THREE-PHASE CHARGING SYSTEMS

A three-phase charging system is used in Honda four cylinder motorcycles. This system is composed of a three-phase A.C. generator, a six-diode rectifier, and a voltage regulator.



The generator is referred to as "three-phase" because it has three single-phase windings spaced so that the voltage induced in each winding is 120° out of phase with the voltage in the other two windings. A representation of the alternating current wave forms (Fig. 27) is similar in appearance to the wave forms which would be generated by three separate single-phase generators (see pages 8 & 9) phased 120° apart.

THREE-PHASE CHARGING SYSTEMS

The three-phase A.C. generator used in Honda GL-1000 engines has two major components; rotor and stator (Fig. 28). The rotor is permanently magnetized and revolves around the stator. Current is generated in the manner described on pages 8 & 9, but the stator windings produce a three-phase output.

Three-phase A.C. generators used in other Honda four cylinder engines have three major components (Fig. 29). The rotor is bolted directly to the end of the crankshaft and revolves in the space between the field coil and stator. The field coil and stator are held stationary in the generator housing.

Unlike other Honda motorcycle generators, the rotor is not permanently magnetized, but is temporarily magnetized through interaction with the field coil. Current from the battery to the field coil determines the strength of the magnetic field and hence the output of the generator.

Voltage Regulation for A.C. Generators Equipped with Field Coils (all Honda four cylinder models except GL-1000):

The voltage regulator (Fig. 30) for these generators provides three operating modes which are selected according to the battery's state of charge. The regulator enables low battery voltage to cause high generator output, and vice versa.

Changes from one operating mode to another are achieved by a relay coil and contact points within the regulator (Fig. 31). The relay coil is an electromagnet (see page 7) which can cause the circuits to be switched by attracting the contact point armature.

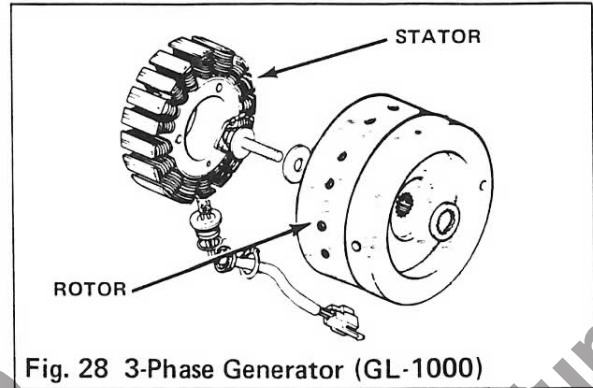

Fig. 28 3-Phase Generator (GL-1000)

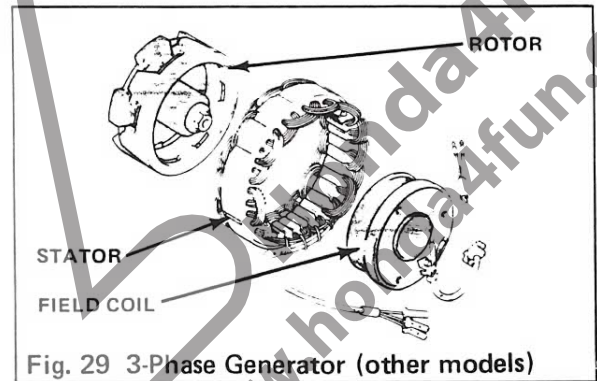

Fig. 29 3-Phase Generator (other models)

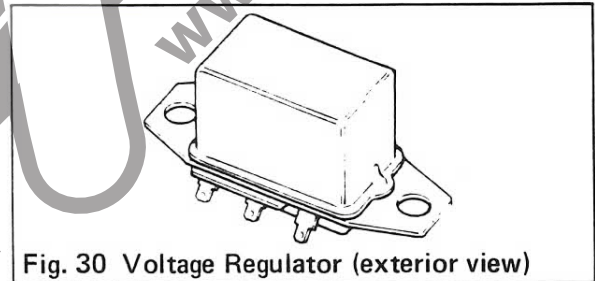

Fig. 30 Voltage Regulator (exterior view)

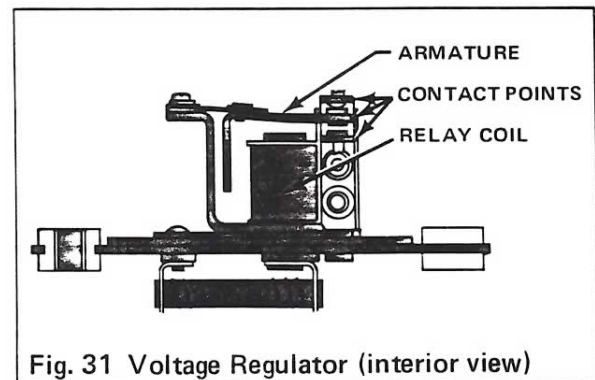

Fig. 31 Voltage Regulator (interior view)

THREE-PHASE CHARGING SYSTEMS

MODE 1 (Fig. 32) – Battery Voltage is Low:

Current flows from the battery to terminal I of the voltage regulator. Inside the regulator, current flows through a relay coil and to ground through terminal E.

Because battery voltage is low (the battery needs charging), there is not enough current flowing through the regulator relay coil to open the contact points, so current also flows from terminal I, through the contact points, through terminal F, and directly to the field coil.

In this mode, the battery is directly connected to the field coil and provides the maximum field current (1.6 amps). Maximum field current causes high generator output for high battery charging voltage.

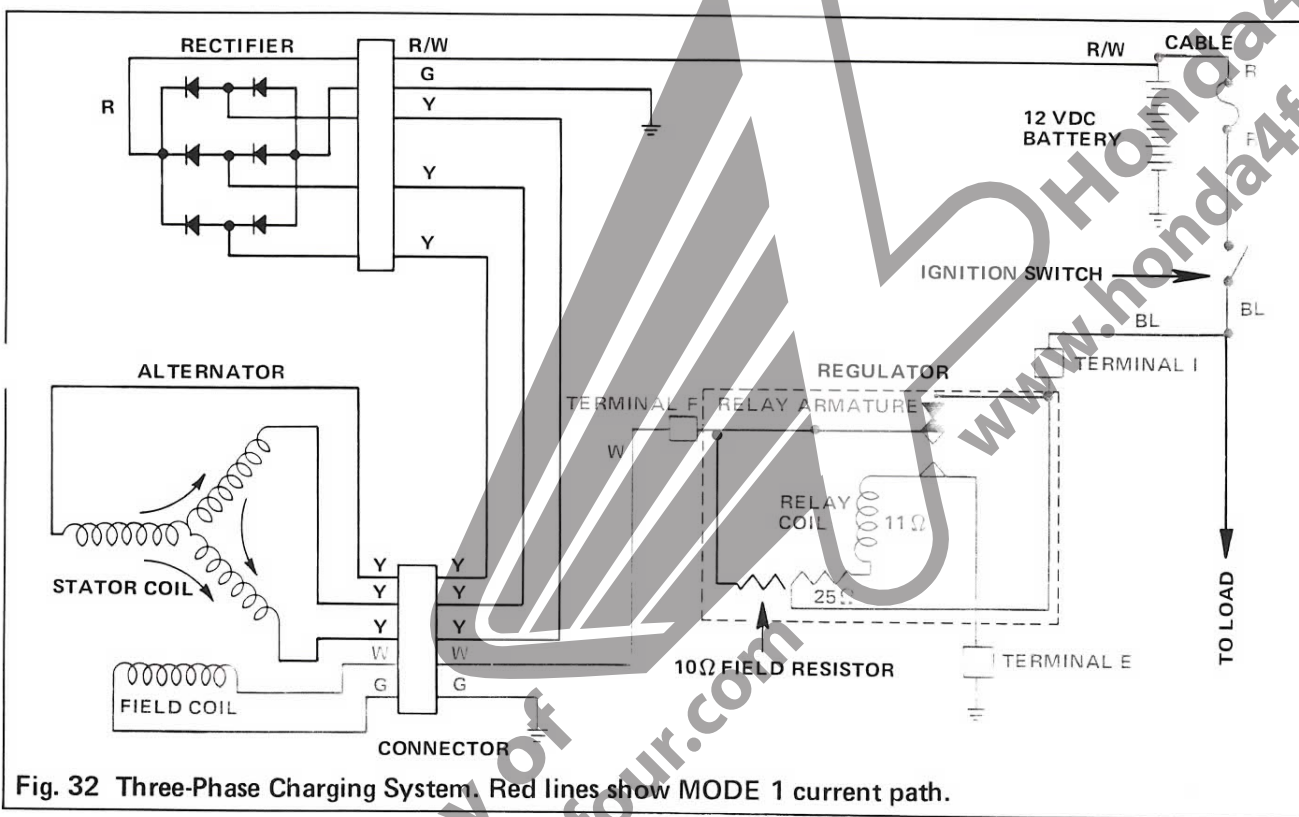

Fig. 32 Three-Phase Charging System. Red lines show MODE 1 current path.

MODE 2 (Fig. 33) – Battery Voltage is Normal:

With normal battery voltage, there is sufficient current flowing through the regulator relay coil to open the contact points. Current may now reach terminal F only by passing through a resistor which reduces field current. Lower field current results in lower generator output.

THREE-PHASE CHARGING SYSTEMS

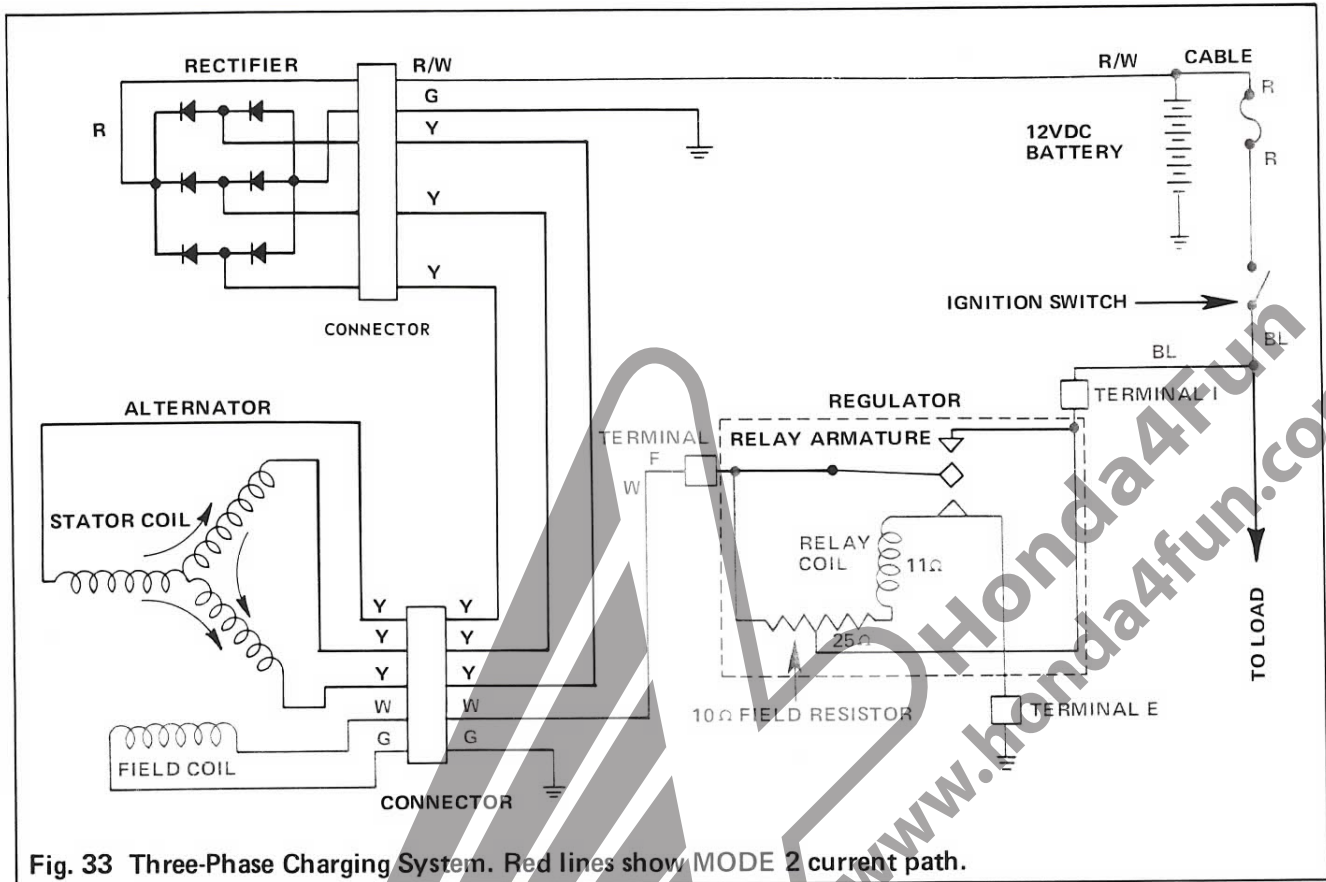

Fig. 33 Three-Phase Charging System. Red lines show MODE 2 current path.

MODE 3 (Fig. 34) – Battery Voltage is Excessive:

When battery voltage is excessive, there is enough current flowing through the regulator relay coil to cause the contact points to complete a ground circuit. Current flows from the battery, through resistance, to ground. No current reaches the field coil, and therefore there is no generator output.

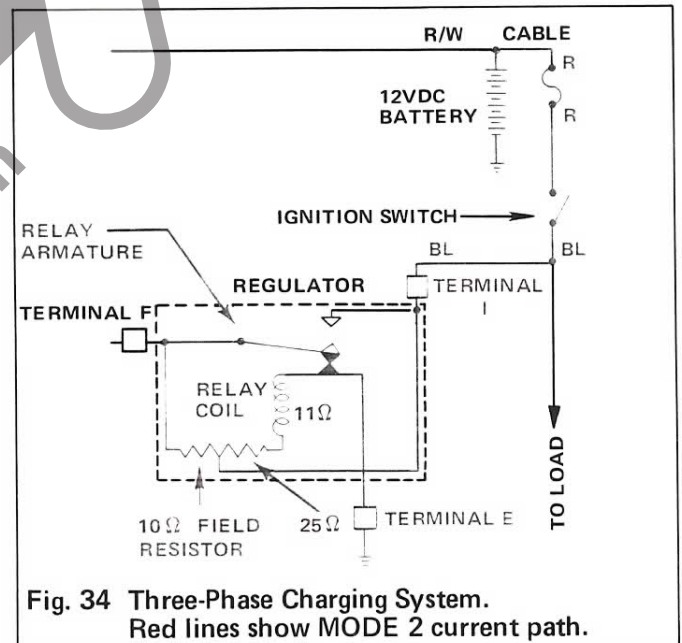

Fig. 34 Three-Phase Charging System. Red lines show MODE 2 current path.

BATTERIES

The battery serves as an energy reservoir, storing the generator's electrical output in chemical form. The battery's chemical energy is converted again to electrical energy for operating the starter motor, or when needed for lighting and ignition current.

When the engine is operating at a speed too low for the generator to supply all the lighting and ignition current needed, the battery discharges, converting its chemical energy into the needed electrical energy. At normal riding speeds, generator output is sufficient to recharge the battery, restoring its chemical energy.

Some motorcycles do not require batteries. Dirt bikes, especially those which have no lighting equipment, do not require an energy reservoir; their ignition current is supplied solely and directly by the generator. These machines are designed without batteries or starter motors for simplicity and to reduce weight.

A battery is required on all motorcycles equipped with starter motors, because the starter motor must operate when the engine is at rest, and the generator cannot supply current until the engine is running. Further, starter motors consume large amounts of current. A battery is also necessary, or at least helpful, if a large amount of lighting current must be delivered at idle speed.

Battery Cell Construction:

Motorcycles are normally equipped with lead-acid batteries. Other metals and electrolytes can be used to construct batteries, but the ordinary lead-acid combination produces the highest cell voltage for the lowest cost.

A simple battery cell is illustrated in Fig. 35. Groups of lead plates are stacked parallel to each other, separated by sheets of insulating material. The cell is filled with dilute sulfuric acid when prepared for service.

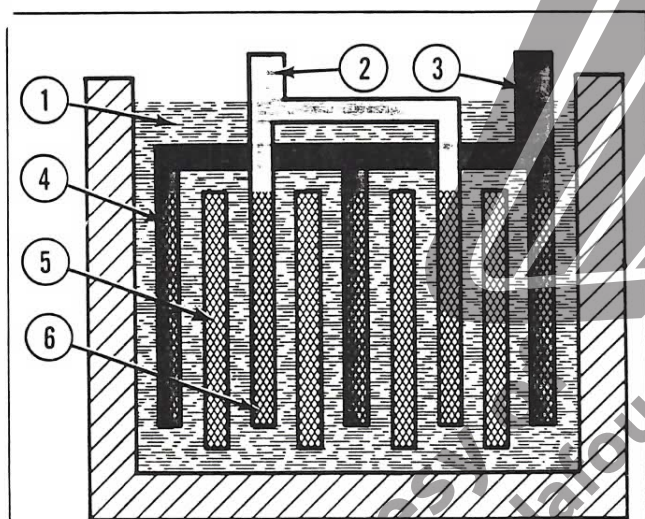

- | | |
|---------------------|--------------------------------------|
| ① ELECTROLYTE | ④ NEGATIVE PLATE (Pb) |
| ② POSITIVE TERMINAL | ⑤ SEPARATOR |
| ③ NEGATIVE TERMINAL | ⑥ POSITIVE PLATE (PbO ₂) |

Fig. 35 Lead-Acid Battery Cell

Plates connected to the negative terminal of the battery are made of plain lead (Pb). Plates connected to the positive terminal are made of lead peroxide (PbO₂), which can be distinguished by its brown color.

The plates are arranged alternately; negative — positive — negative, etc. There is a negative plate at each end of the plate group; therefore the cell has one more negative plate than positive plate. There is no technical reason for using negative plates at both ends; it is simply common practice.

Separator sheets of resin treated paper and fiberglass, or other non-conductive materials, are porous to permit the passage of electrolyte, while insulating the lead plates from each other to prevent short circuiting. Additional separators may be placed at the ends of the plate group as packing material, though this is not essential.

Battery Cell Operation:

Chemical action between the electrolyte and the cell plates produces an electric current. As previously stated, the positive cell plates are lead peroxide (PbO_2) and the negative cell plates are plain lead (Pb). When a load is connected between the battery terminals and the cell discharges, the sulfuric acid electrolyte (H_2SO_4) divides into H_2 and SO_4 . The H_2 combines with oxygen in the positive plates to form water (H_2O), while the SO_4 combines with the lead (Pb) of both plates to form lead sulfate (PbSO_4). When the battery is recharged by the generator, the chemical process is reversed.

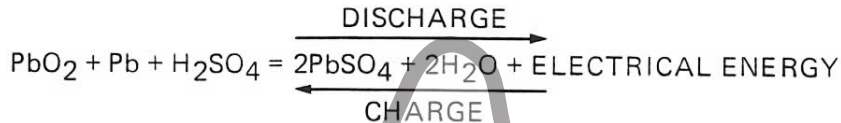

As discharge continues, the amount of lead sulfate on the plates increases until the sulfate coating becomes so thick that the weakened electrolyte cannot effectively reach the active materials (lead and lead peroxide). When this happens, chemical reaction is retarded and the output of the cell is reduced. In practice, the battery should not be permitted to discharge to this extent, because thick coatings of lead sulfate are difficult to remove in charging. When a battery has been allowed to remain in a discharged condition for a considerable time, sulfation is visible as a white deposit on the plates. Cells which have become badly sulfated may be permanently impaired.

Specific Gravity:

When the cell is being charged, lead sulfate is removed from both positive and negative plates, and sulfuric acid is again formed. In the process, the water content of the electrolyte is decreased, and the acid content of the electrolyte is increased.

Sulfuric acid is heavier than water. Therefore, increasing the sulfuric acid content increases the density of the electrolyte. *Specific gravity* is a measure of the density of the electrolyte, relative to water. Water has a specific gravity of 1.000.

The cell's state of charge is indicated by the specific gravity (density) of its electrolyte and can be checked with a hydrometer (Fig. 36).

The specific gravity must be high enough to promote chemical action in the cell, though excessive acid content can shorten cell life. A well charged cell in a motorcycle battery should have a specific gravity of 1.260 – 1.280. A specific gravity of 1.200 – 1.260 indicates a partial charge. If the specific gravity falls below 1.200, the battery should be recharged as soon as possible; it should not be permitted to remain for a long time in a discharged state.

The specific gravity figures given in the preceding paragraph apply at a standard reference temperature of 77°F. The specific gravity reading for a given electrolyte density will vary slightly with temperature changes. At high temperatures, lower specific gravity readings will be obtained, and vice versa.

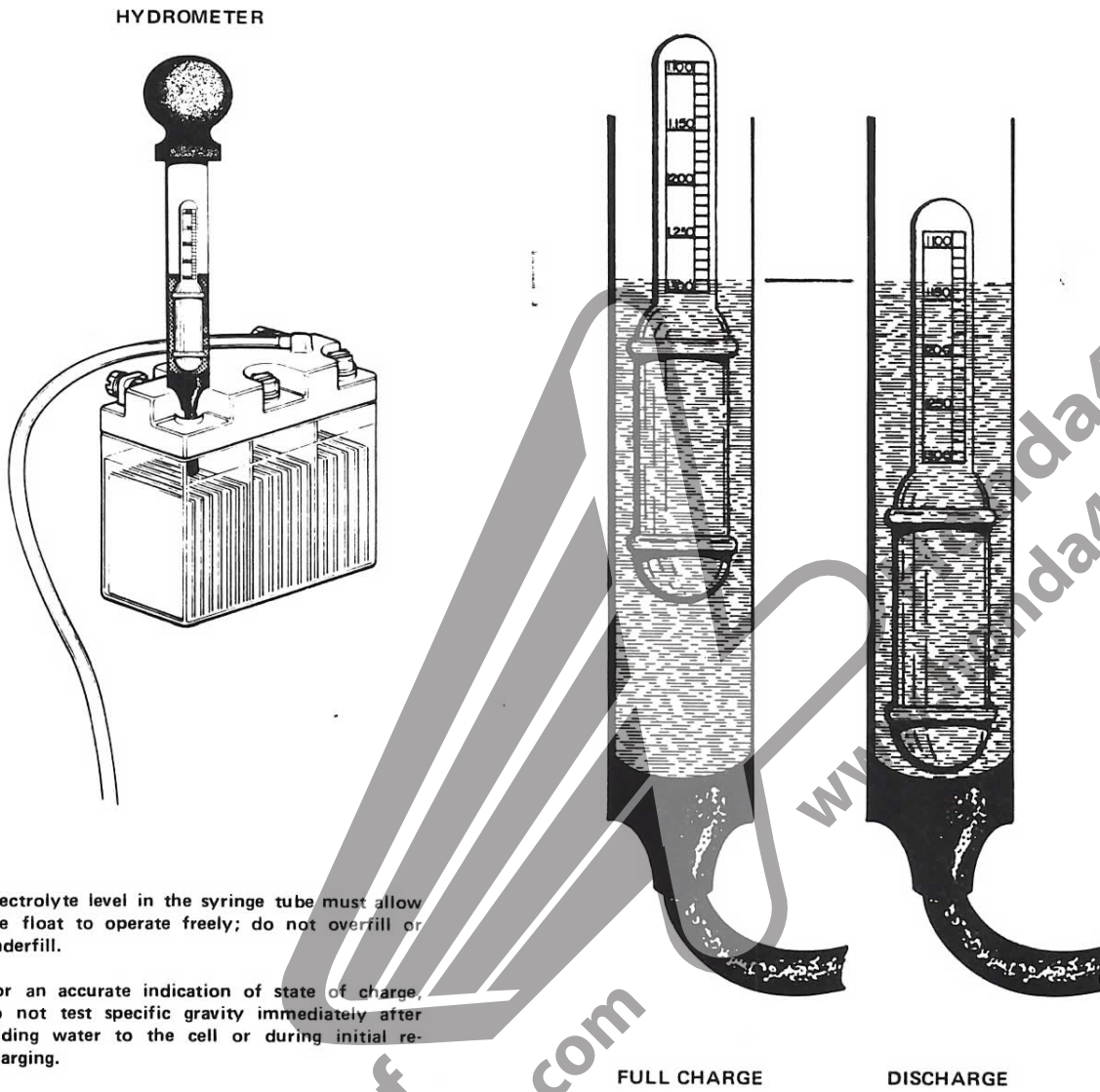

Fig. 36 Measuring Specific Gravity With a Hydrometer (calibrated float reads specific gravity)

As a temperature correction factor, add 0.001 to the specific gravity reading for each 3°F above 77°F. Subtract 0.001 from the specific gravity reading for each 3°F below 77°F. Thus, if a specific gravity reading of 1.260 is obtained at 50°F, the corrected specific gravity is 1.251.

Battery Cell Voltage:

Cell voltage is basically determined by the plate material and electrolyte chemicals used. A lead-acid cell produces a nominal 2 volts.

Regardless of cell size or the number of cell plates (these factors affect ampere-hour capacity), if the plates are lead and the electrolyte is sulfuric acid, then the nominal cell voltage is 2 volts.

Three 2 volt cells are connected in series to make a 6 volt battery (Fig. 37). Six 2 volt cells are connected in series to make a 12 volt battery (Fig. 38).

Note that the cells must be connected in *series* in order for the cell voltages to be additive. If a number of 2 volt cells were connected in *parallel*, you would simply have a large 2 volt battery with greater ampere-hour capacity.

The actual, measured voltage of a lead-acid cell will be slightly more or less than the nominal 2 volts, depending on the specific gravity of the electrolyte.

Open circuit voltage, applicable while the battery is not connected to any load, can be calculated as follows:

$$\text{VOLTS} = \text{SPECIFIC GRAVITY} + .84$$

Thus, the open circuit voltage for a cell with a specific gravity of 1.280 is 2.12 volts. Six such cells, connected in series, will produce a battery open circuit voltage of 12.72 volts.

When a cell discharges, there is a gradual decrease in voltage due to increasing internal resistance as lead sulfate coats the plates and electrolyte weakens. After a gradual decrease to roughly 1.75 volts, the cell's capability is exhausted, and voltage drops sharply below a useful level.

Voltage generated by the motorcycle's charging system must be greater than the battery's nominal voltage. Charging voltage must equal the battery's open circuit voltage plus the voltage necessary to overcome internal resistance within the cells.

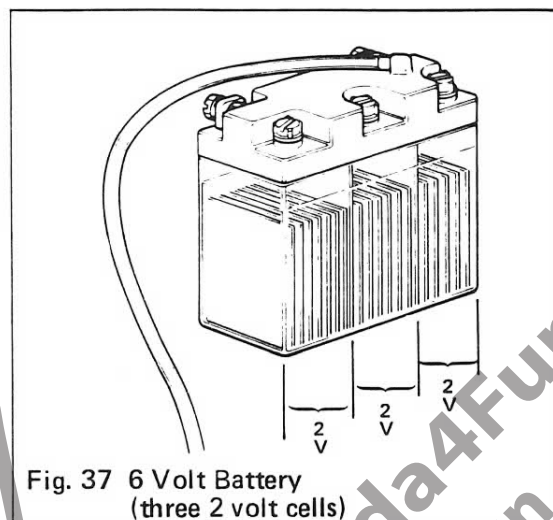

Fig. 37 6 Volt Battery
(three 2 volt cells)

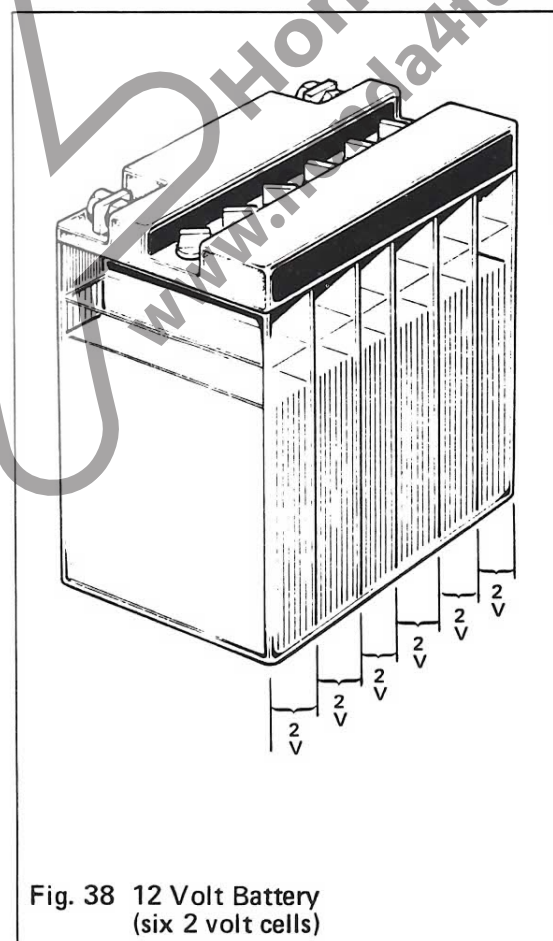

Fig. 38 12 Volt Battery
(six 2 volt cells)

BATTERIES

B. Battery Ampere-Hour Capacity:

Battery capacity (the ability to deliver electrical energy) is expressed in terms of *ampere-hours*. Ampere-hour ratings are calculated by multiplying battery discharge current, in amperes, times the number of hours the battery is capable of supplying that current.

However, in order for a battery's advertised ampere-hour rating to have any meaning, it is essential to know the particular time period for which the ampere-hour rating was measured. If a battery is slowly discharged, producing low amperage current over a period of many hours, it will produce far more ampere-hours of current than if it is discharged at a very rapid rate, such as occurs when operating a starter motor.

A 12 ampere-hour battery, based on a 10 hour discharge rate, will deliver 1.2 amperes of electrical current for a 10 hour period ($1.2A \times 10 \text{ hrs.} = 12 \text{ ampere-hours}$). The same battery will **not** deliver 12 amperes for 1 hour; more likely it would deliver about half that much at a 1 hour discharge rate.

For Yuasa batteries used in Honda motorcycles, a period of 10 hours has been established as the discharge time in rating battery capacity. American automotive batteries customarily use a 20 hour rate for advertised ampere-hour capacity. A 5 hour rate is standard for aircraft batteries.

The ampere-hour capacity of a battery depends mainly on its total effective plate area. A larger battery, with bigger plates or more plates in parallel, will have a higher ampere-hour capacity. Greater ampere-hour capacity can also be obtained by connecting two or more batteries in *parallel*. A battery will also have a somewhat higher ampere-hour capacity at summer temperatures than at winter temperatures, because higher temperatures accelerate chemical reaction. However, cell temperatures in excess of 113°F (45°C) will reduce the service life of the battery.

Battery Identification:

A model identification code is imprinted on the side of all Yuasa motorcycle batteries (Fig. 39). In most (but not all) cases, this code will correspond to the JIS (Japan Industrial Standards) classification number for that type of battery.

Where Japanese-made batteries are concerned, technical literature and battery interchangeability charts usually refer to the JIS number, and it is useful to know how to decipher the code.



Yuasa 12N12A-4A-1 Battery

Number preceding letter "N" indicates battery voltage. Number immediately following "N" indicates ampere-hour capacity. Other symbols identify the physical construction of the battery.

12N12A-4A-1 CODE INTERPRETATION

- 12— Nominal voltage (12 volts)
- N — Initial for Nippon (Japan)
- 12— Ampere-hour capacity at 10 hour discharge rate (12 AH)
- A — JIS battery identification symbol
- 4 — Terminal position code
- A — Vent tube position code
- 1 — Yuasa battery identification number

6N6-3B CODE INTERPRETATION:

- 6 — Nominal voltage (6 volts)
- N — Initial for Nippon (Japan)
- 6 — Ampere-hour capacity at 10 hour discharge rate (6 AH)
- 3 — Terminal position code
- B — Vent tube position code

Fig. 39 Battery Identification Codes

Dry-Charged Batteries:

Yuasa batteries for Honda motorcycles are *dry-charged*, which means that the cell plates are charged and then dried before the battery is assembled by the manufacturer. Assembled batteries are sealed to keep out moisture. This process enables batteries to be stored for long periods of time without deterioration.

Preparation of New Dry-Charged Motorcycle Batteries:

1. Unseal the battery and attach the vent tube. The vent tube must be unobstructed in order to vent hydrogen and oxygen that is liberated during the charging process (see page 22).

If the vent tube is kinked, it should be reshaped prior to use. A kinked vent tube will usually regain its shape if immersed in boiling water for a few minutes.

2. Fill the battery cells with electrolyte and let stand for 1 or 2 hours. Adjust electrolyte level to the upper level line marked on the battery case.

In cold weather, electrolyte should be brought to room temperature before filling the battery.

BATTERIES

3. Charge the battery at one tenth (10%) of its rated ampere-hour capacity for the number of hours shown in the following chart. For example, a 12 ampere-hour battery that is 6 months old should be charged at 1.2 amps for 3 hours.

INITIAL CHARGE FOR NEW BATTERIES

Months elapsed since manufacture*	Charging hours
Less than 12 months	3 hours
12 to 18 months	5 hours
18 to 24 months	10 hours
More than 24 months	15 - 20 hours

*Date of manufacture is stamped on the battery case, below gas vent.

NOTE: If the battery seal is missing, or was removed more than one day prior to activation, charge the battery for 15 - 20 hours.

CAUTION: Do not exceed the recommended charging rate (10% of the battery's ampere-hour rating), and do not allow electrolyte temperature to exceed 113°F (45°C) during the charging process. Excessive charging rate and cell temperature will damage the battery.

Electrolyte Level:

Check electrolyte level every week or so. When the electrolyte level becomes low, add water until the electrolyte reaches the upper level line marked on the battery case. Never allow the electrolyte level to fall so low as to expose the cell plates, as this can damage the plates.

Water loss is a result of the normal charging process. As the cells approach full charge and cannot utilize further current for the chemical changes described on page 17, the excess charging current breaks down electrolyte water into its hydrogen and oxygen components. This can be seen through the transparent battery case as bubbles rising to the top of the cells. These gases escape through the vent tube. Minute amounts of acid inadvertently escape through the vent tube as well. The volume of acid lost in this manner is so small that acid replenishment is never required during the service life of the battery. However, the vent tube must be routed so that it does not discharge near the drive chain or other critical parts that are susceptible to acid damage.

It is preferable to use distilled water in the electrolyte solution. Tap water may contain chlorine, iron, and other elements which would contaminate the electrolyte and reduce its effectiveness.

Battery Vent Tube:

Route the battery vent tube as described in the owner's manual for your motorcycle model. Correct routing is also shown on caution labels (Fig. 40 & 41) attached near the battery area of Honda motorcycles.

It is important that the vent tube be routed so it is not kinked or pinched, and it must be positioned where it cannot discharge acid fumes and droplets on the drive chain. If acid contacts the drive chain, premature wear or breakage may occur (Fig. 42).

Check the battery vent tube occasionally to be sure that it is properly attached and has not become kinked or pinched. Replace damaged vent tubes.

Battery Cleaning:

Inspect battery terminals and the battery mounting box for signs of corrosion. Clean and repaint the battery box if signs of corrosion appear. Clean all corrosion from the battery terminals. Battery terminals can be coated with petroleum jelly for corrosion protection, but do not allow petroleum jelly to coat the battery case. A solution of baking soda (sodium Bicarbonate) and water can be used to neutralize acid when cleaning the battery and its mounting box.

Soapy water (using mild bar soap) is recommended for general cleaning. If the battery fits tightly in its mounting box, soapy water can also be used to ease installation and removal. No other cleaning agents should be used. Some cleaning and lubricating products contain chemicals which may cause the battery case to weaken or crack. Aerosols and petroleum base products are especially harmful.

CAUTION: Cell caps must be installed when cleaning the battery. Do not allow soap or baking soda to enter battery cells.

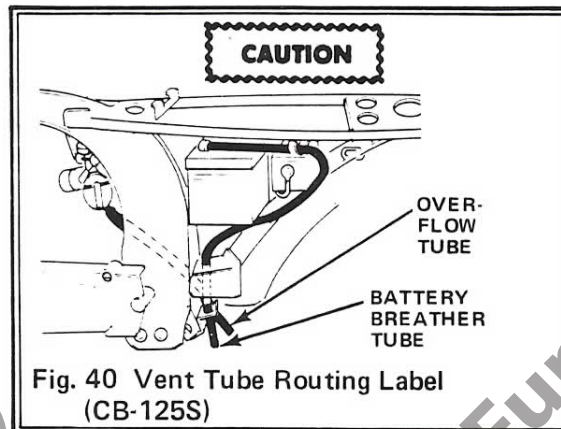

Fig. 40 Vent Tube Routing Label (CB-125S)

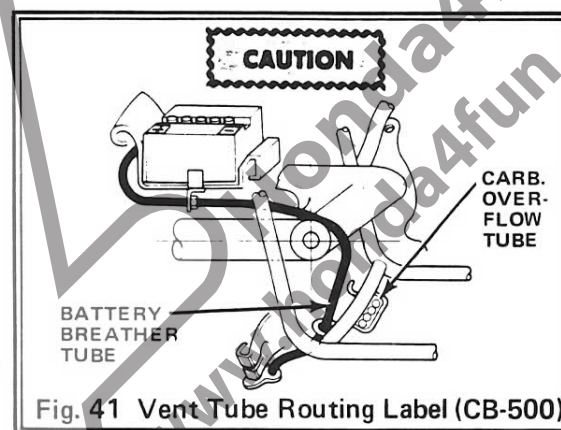

Fig. 41 Vent Tube Routing Label (CB-500)

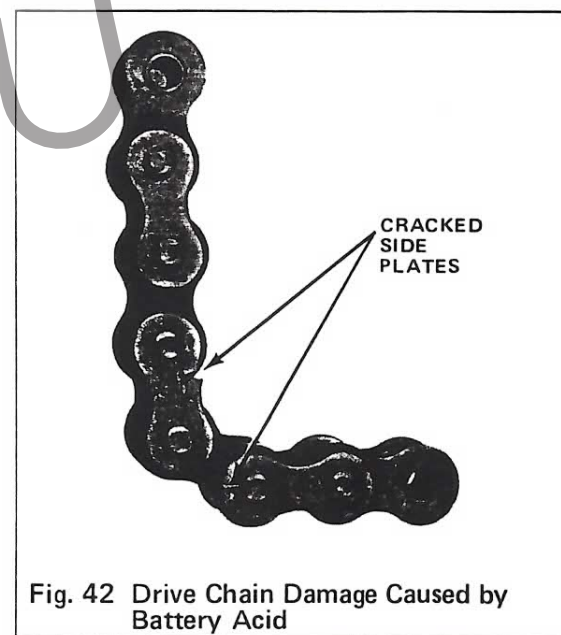

Fig. 42 Drive Chain Damage Caused by Battery Acid

BATTERIES

Battery Storage:

When a battery is not in use, it discharges at an average rate of $\frac{1}{2}\%$ per day. The rate of self-discharge is greater at warm temperatures and less at cold temperatures.

If your motorcycle is to be stored for only a few weeks, disconnect the negative battery cable to prevent possible current leakage within the motorcycle's electrical system. Self-discharge will still occur within the battery, but the amount of discharge will not be substantial over a period of only a few weeks.

If your motorcycle is to be stored for a month or longer, remove the battery from the motorcycle, store it in a cool, dry location, and recharge it at least once a month. A hydrometer can be used to determine the battery's state of charge and establish the best recharging intervals. Never allow the battery to stand in a discharged condition for long periods, or the cell plates will be affected by sulfation. Be sure the battery is fully charged when it is again placed in service.

Battery Charging Equipment:

Recommended charging current for Honda motorcycle batteries (10% of the battery's ampere-hour capacity) ranges between 0.2 and 2.0 amperes, depending upon the ampere-hour capacity. Most of the inexpensive automotive trickle chargers are not suitable, as they generally deliver a current of one to six amperes. An excessively high charging current will damage the battery.

If you are unable to obtain a battery charger with sufficiently small output for your motorcycle battery, you can modify an automotive battery charger to deliver a suitable charging current by connecting a 12 ohm, 50 watt rheostat and an appropriately calibrated ammeter as shown in Fig. 43.

Adjust the rheostat to deliver the recommended amperage. Relatively inexpensive rheostats and ammeters are available from electronics parts supply stores. For a neat, permanent installation, the ammeter and rheostat can be built into a small box next to the charger, but adequate ventilation must be provided to cool the rheostat.

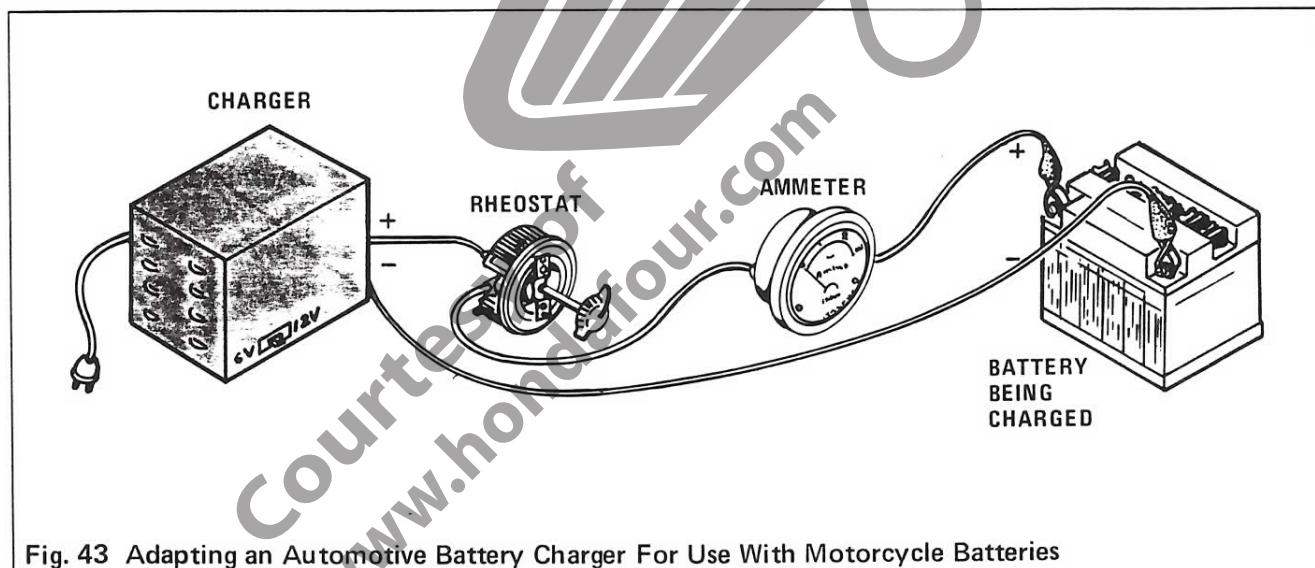

Fig. 43 Adapting an Automotive Battery Charger For Use With Motorcycle Batteries

Battery Safety:

Battery electrolyte contains sulfuric acid. Do not allow electrolyte to contact skin, eyes, or clothing. For safety, wear eye protection when working with batteries and electrolyte. Keep batteries and electrolyte out of reach of children.

ANTIDOTE, external: Flush with water. If electrolyte has contacted the eyes, flush with water and get immediate medical attention.

ANTIDOTE, internal: Drink large quantities of water or milk. Follow with milk of magnesia, beaten egg, or vegetable oil. Call a physician immediately.

Editorial Note: Electrolyte has a pungent, sour flavor; it tastes really terrible. We cannot imagine why anyone would want to drink the contents of their battery, but our legal staff feels that an antidote should be published in case this might occur anyway. Drinking your battery can be fatal, or certainly more harmful than eating your saddle, or biting your tires. We watch our legal staff very closely to be certain they do none of these things, though tire biting is not particularly harmful unless the motorcycle is in motion.

Batteries produce highly explosive hydrogen gas during the charging process. Be sure the battery vent tube is unobstructed, and the battery charging area is well ventilated. Keep open flames and sparks away from the battery. To prevent sparks, switch off or unplug the battery charger when connecting or disconnecting the battery.

When removing the battery from the motorcycle, disconnect the negative cable first. This procedure eliminates the chance of short circuiting the battery if your wrench or screwdriver should touch the motorcycle frame while loosening the positive cable connection. When installing the battery, connect the negative cable last.

IGNITION SYSTEMS

Basically, a motorcycle ignition system consists of a voltage source (battery or A.C. generator), a switching device to start and stop current flow at predetermined intervals (contact points or an electronic switch), a step-up transformer to produce high voltage (ignition coil), and the spark plug.

The sole purpose of the ignition system is to produce a spark that will ignite the air-fuel mixture in the engine's combustion chamber. The spark must be timed to occur at a precise point relative to the compression stroke of the piston.

In order to produce the ignition spark, an electric current must be made to jump the gap between the spark plug electrodes in the highly pressurized atmosphere of the combustion chamber.

IGNITION SYSTEMS

Electrical current produced directly by the battery or A.C. generator will not jump the spark plug gap because the electrical pressure (voltage) is too low to overcome such resistance. Thousands of volts are required to make an electrical current jump the spark plug gap. This voltage requirement varies according to spark plug design, gap width, spark plug condition, and operating factors, but for dependable performance, the ignition coil should be capable of producing at least 15,000 volts.

Low voltage current, produced by the battery or A.C. generator, flows to the ignition coil at intervals determined by the contact points (or electronic switch) and is transformed by the ignition coil into high voltage current which jumps the spark plug gap.

Ignition systems in use on various motorcycles differ primarily in regard to the voltage source, battery or A.C. generator, which in turn affects the specific design of other ignition components. Other differences concern the method chosen for inducing high voltage and whether the system incorporates electronic circuitry.

As we have seen in preceding sections of this manual, motorcycle batteries produce a nominal 6 or 12 volts of *direct current*, while A.C. generators produce *alternating current*. A.C. generator voltage is determined by the number of windings, strength of magnetic field, and engine rpm (see page 8), though for ignition purposes, generator voltage is in a relatively low range and must be transformed into high voltage before it goes to the spark plug.

An A.C. generator that serves as the voltage source for ignition is commonly called a *magneto*, and ignition systems are normally classified as being either "battery" or "magneto". In motorcycles without lighting equipment or batteries, the A.C. generator may function solely as a magneto. In other models one A.C. generator coil may be used for magneto functions, while another coil, or coils, within the same A.C. generator may provide lighting and battery charging current.

Magnetos can be classified as being "high tension", "low tension", or "energy transfer".

A *high tension magneto* (page 29) incorporates the function of an ignition coil within the magneto windings. High voltage is induced in the magneto secondary windings by a rapid *collapse* of the magnetic field surrounding the magneto primary windings. The high voltage so induced is sent directly to the spark plug. No separate ignition coil is used.

A *low tension magneto* (page 30) is essentially a high tension magneto without integral secondary windings. The contact points are connected in series with the primary windings of a separate ignition coil.

An *energy transfer* system (page 31) is similar to a low tension magneto system, except that the contact points are connected in parallel with the A.C. generator windings. High voltage is induced in the secondary windings of a separate ignition coil upon the rapid *build-up* of the magnetic field surrounding the ignition coil primary windings.

Some technical publications treat the energy transfer system as a separate category apart from battery or magneto systems. Some publications, including the one you are now reading, classify the energy transfer system as another kind of magneto, since it obviously isn't a battery system. Still other publications, including manuals by the U.S. Department of Transportation, do not use the term "energy transfer" at all, considering it to be merely a variant of the low tension magneto system. Different usage of the term "magneto" and different categorization of the term "energy transfer" create much confusion. It is unusual for any two technical publications to use these terms in the same way.

Honda motorcycles are equipped with either battery ignition systems or energy transfer systems. The high tension magneto system and the low tension magneto system are sometimes encountered on motorcycles of other manufacture, but not Honda. Therefore, if you hear or read the term "magneto" used in reference to Honda motorcycles, it necessarily refers to the energy transfer system. All types of ignition systems, battery, high tension magneto, low tension magneto, and energy transfer, may be encountered on Honda Power Products.

Battery Ignition:

The battery ignition system used in Honda motorcycles is illustrated in Fig. 44. This illustration is simplified to clearly show how the basic system functions. Actual connections and circuit paths for specific models may not conform exactly to Fig. 44 but are shown in shop manuals for the individual models.

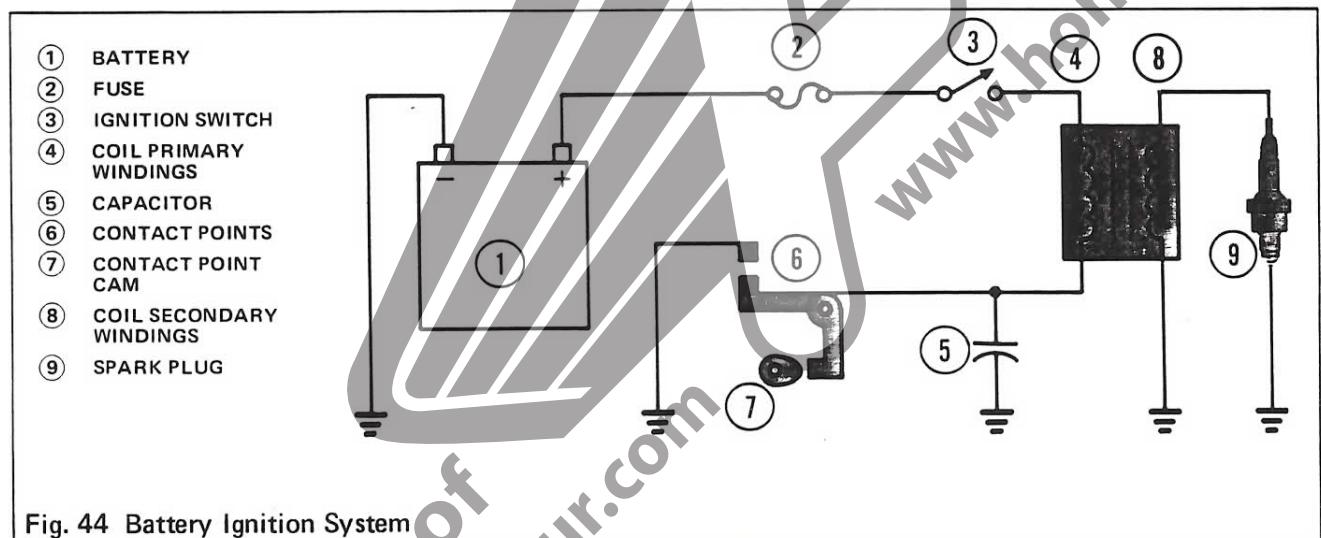

Fig. 44 Battery Ignition System

The *primary* ignition circuit starts at the battery (1) and runs through fuse (2), ignition switch (3), coil primary windings (4), contact points (6), and to ground, completing the primary circuit. A capacitor (5) (also called a condenser) is connected at a point between the coil primary windings and the contact points. The other end of the capacitor is grounded.

The *secondary* ignition circuit starts in the ignition coil secondary windings (8) and runs through the spark plug (9) to ground, completing the secondary circuit.

IGNITION SYSTEMS

The contact points (6) (page 27) are connected in series with the primary circuit. When the ignition switch (3) is turned on, the contact points open and close the primary circuit as the contact point cam (7) rotates. While the contact points are closed, current flows through the primary windings (4) of the ignition coil, establishing a magnetic field. When the contact points open, the circuit is broken, and the magnetic field rapidly collapses, inducing current in the secondary coil windings (8) (see Induction, page 8).

The induced secondary current jumps the spark plug gap, creating the spark to ignite the air-fuel mixture in the cylinder. Secondary voltage is far greater than voltage through the primary circuit because there is a far greater number of secondary coil windings than primary windings. One of the principles of induction, stated on page 8, is that the strength of induced voltage is partly determined by the number of windings which cut the magnetic field.

As the contact points open, the effect of the collapsing magnetic field in the ignition coil also creates some voltage surge in the primary circuit. The capacitor (5) (page 27) absorbs this voltage surge and thus helps to prevent the contact points from arcing as they separate.

The contact points must be prevented from arcing for two reasons. Firstly, arcing causes the contact points to become pitted and burnt, greatly reducing their service life. Secondly, arcing allows the primary current to continue to flow for an instant after the points start to open, thus decreasing the speed with which the coil's magnetic field collapses and decreasing the induced voltage in the secondary windings. The use of a capacitor allows the primary circuit to be broken with a minimum of arcing to extend contact point service life and hasten the collapse of the coil's magnetic field.

Incidentally, the ignition coil steps down amperage by the same ratio that it steps up voltage. High voltage (electrical pressure) is required to jump the spark plug gap, but amperage is of little consequence in this application. If you inadvertently touch an uninsulated spark plug terminal while the engine is running, the high voltage shock will make you flinch, but unless you have a heart condition, the amperage (current flow) is too low to really harm you.

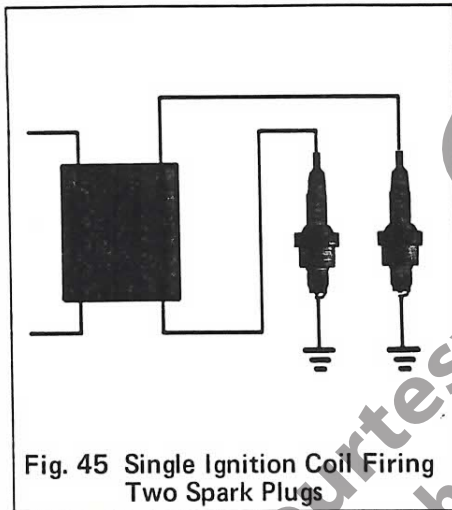

Fig. 45 Single Ignition Coil Firing Two Spark Plugs

There are several models of Honda motorcycle in which a single ignition coil is used to fire two spark plugs. This is achieved by connecting a spark plug to each end of the ignition coil's secondary windings, as shown in Fig. 45. In this hook-up, both spark plugs are wired in series with the secondary coil windings, and both plugs fire simultaneously.

Where two spark plugs are fired by a single coil, the plugs are used in cylinders whose firing order is 360° apart. Thus, one spark plug will fire while its cylinder is near the top of its compression stroke, and the other spark plug will fire simultaneously while its cylinder is near the top of its exhaust stroke. Spark plugs connected in this manner fire twice as often as necessary (no purpose is served by firing on the exhaust stroke), but this design greatly simplifies the ignition system, eliminating the need for a distributor, or for additional sets of contact points, capacitors, and coils for each cylinder.

High Tension Magneto Ignition:

The high tension magneto system does not use a separate ignition coil. High voltage is induced in the magneto secondary windings by the collapsing magnetic field that surrounds the magneto primary windings.

All magneto systems operate without a battery, or independent of the battery if one is provided for other electrical functions.

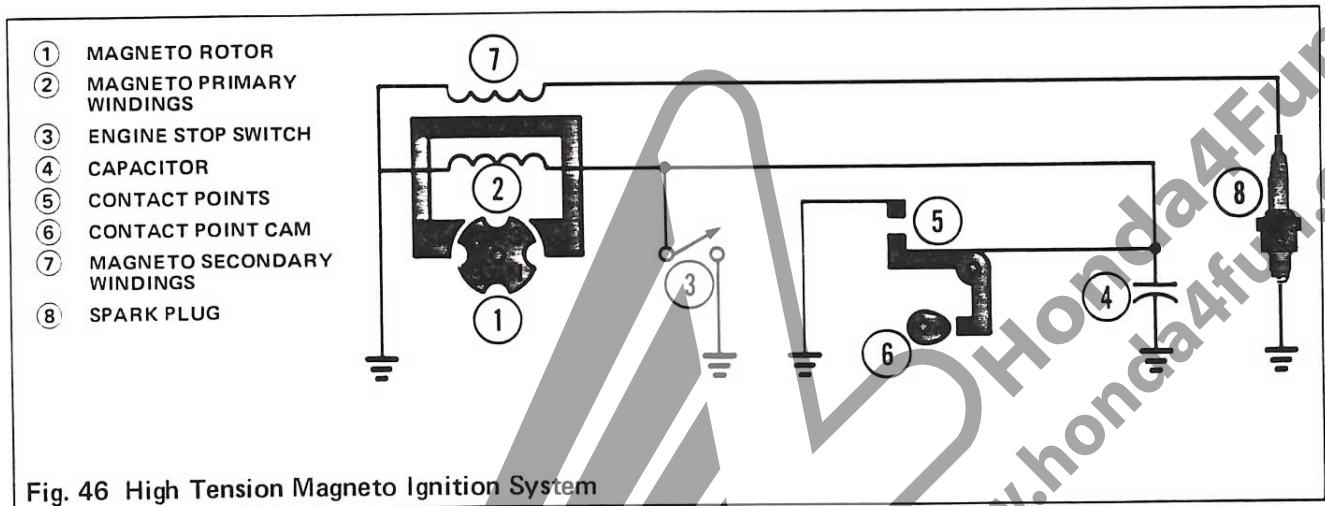

Fig. 46 High Tension Magneto Ignition System

Between firing impulses, the contact points (5) remain closed, completing the primary circuit. As the magneto rotor (1) spins, alternating current is induced in the magneto primary windings (2), the same as in any A.C. generator (see A.C. Generator Operation, page 8). Magnetic lines of force are built up, collapsed, and then built up again in the opposite direction.

As the magnetic field in the primary circuit collapses, current is induced in the magneto secondary windings. However, if the primary circuit were operated as a simple A.C. generator, the collapse would not be sufficiently rapid to induce usable ignition voltage, so the contact point cam (6) is timed to open the contact points (5) just as the magnetic field collapses. Opening the contact points breaks the primary circuit, hastening the collapse of the magnetic field. *Rapid* collapse of the magnetic field induces high voltage in the magneto secondary windings (7) which flows through the spark plug (8). The capacitor (4) protects the contact points and helps to hasten the collapse of the magnetic field, as in other ignition systems.

When the engine stop switch (3) is closed, the contact points have no effect. The primary circuit remains unbroken, and the magnetic field will not collapse rapidly enough to induce ignition voltage.

IGNITION SYSTEMS

Low Tension Magneto Ignition:

The low tension magneto system uses a separate ignition coil to induce high voltage. Operation is otherwise similar to the high tension magneto system described on page 29. Note that the contact points in both high and low tension magneto systems are connected in series with the primary circuit, as opposed to the energy transfer system (page 31) in which the contact points are connected in parallel with the primary circuit.

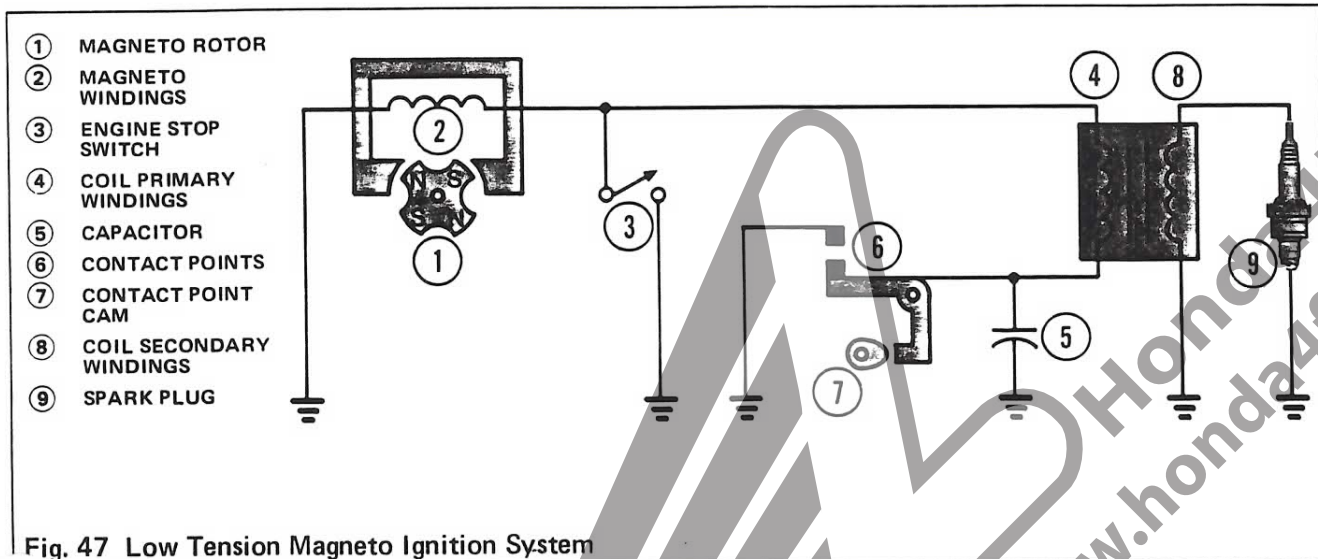

Fig. 47 Low Tension Magneto Ignition System

The contact points (6) close to complete the primary circuit. The magneto rotor (1) spins, inducing current in the magneto windings (2) which flows through the ignition coil primary windings (4), establishing a magnetic field in the ignition coil.

Because the magneto is an A.C. generator, current flow will reverse direction as the rotor (1) spins. Reversal of current flow collapses the magnetic field in the ignition coil, but does not collapse it rapidly enough to induce usable ignition voltage. The contact point cam (7) is synchronized with the magneto rotor (1) to open the contact points (6) at this time, breaking the primary circuit and hastening the collapse of the magnetic field in the ignition coil. *Rapid* collapse of the magnetic field induces high voltage in the coil secondary windings (8) which flows through the spark plug (9). The capacitor (5) protects the contact points and helps to hasten the collapse of the magnetic field.

The engine stop switch (3) can be closed to short circuit the magneto, stopping the engine.

Energy Transfer Ignition:

Operation of the energy transfer system differs from the low tension magneto system by having contact points connected in parallel with the primary circuit and contact point timing which results in secondary voltage being induced by the rapid *build-up* of a magnetic field. Note that battery ignition systems, high tension magneto ignition systems, and low tension magneto systems all induce secondary voltage by the rapid *collapse* of a magnetic field, while the energy transfer system induces secondary voltage by the rapid *build-up* of a magnetic field.

The term "energy transfer" is a misnomer for the circuit shown in Fig. 48. However, application of the term to this circuit is justified by common use and serves to distinguish this circuit from other magneto ignition circuits.

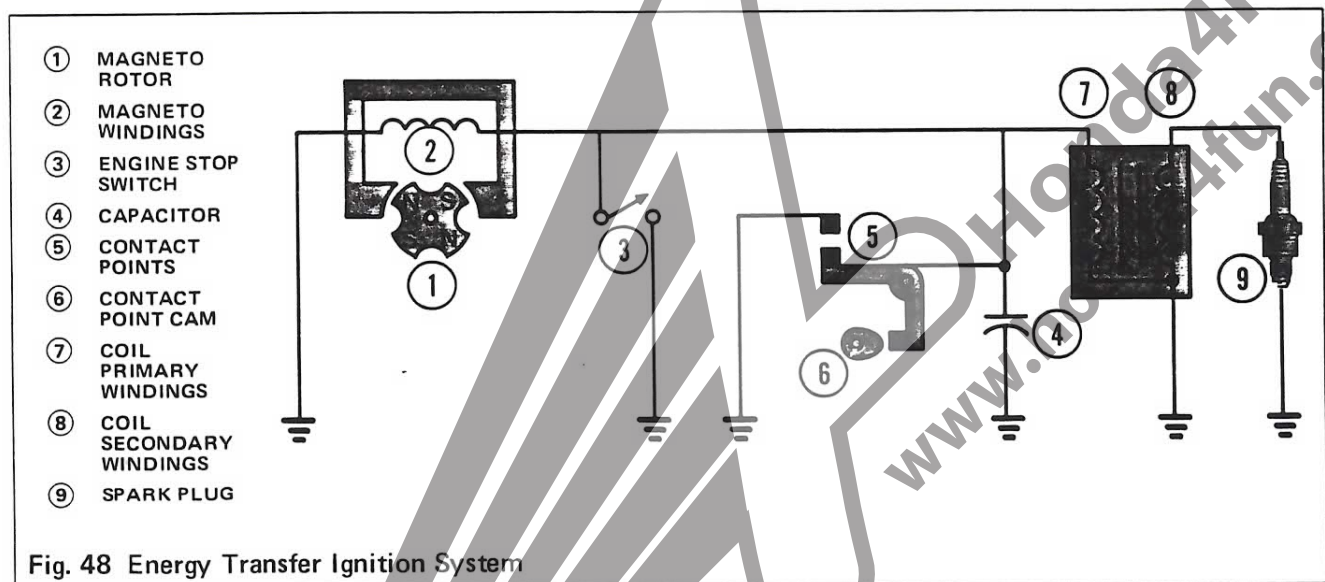

Primary voltage is supplied by the magneto or A.C. generator (whichever term you prefer). Between firing impulses, the contact points (5) remain closed, short circuiting all current produced by the magneto. Thus, no current energizes the ignition coil primary windings (7). The same effect can be obtained manually by closing the engine stop switch (3).

The contact point cam (6) is synchronized with the magneto rotor (1) to open the contact points (5) when the magneto's output wave (see Fig. 23, page 10) is at or near its peak. When magneto output reaches its peak and the contact points (5) open, a surge of current flows through the ignition coil primary windings (7), causing rapid *build-up* of a magnetic field which induces high voltage in the ignition coil secondary windings (8). The high voltage so induced then flows through the spark plug (9). The capacitor (4) protects the contact points and enables them to break the circuit quickly with a minimum of arcing.

IGNITION SYSTEMS

Capacitor Discharge Ignition (CDI):

A capacitor has the ability to temporarily store and quickly discharge electrical energy. Any ignition system which discharges a capacitor into the primary windings of the ignition coil for the purpose of inducing secondary voltage is, by definition, *capacitor discharge ignition*. Capacitor discharge ignition comes in many forms and may be incorporated in either battery or magneto systems.

Some systems use a battery as the primary voltage source, but send battery voltage through a converter before it reaches the capacitor, the idea being to produce higher voltage than would otherwise be possible. Some systems use a magneto as the primary voltage source to charge the capacitor, and the capacitor discharges whatever magneto voltage it received.

In any case, capacitor discharge ignition customarily uses an electronic switch to trigger the capacitor instead of contact points. Tune-ups are greatly simplified when there are no contact points to adjust or replace. Fig. 49 is a simplified illustration of the capacitor discharge ignition system used on the Honda CR-125M.

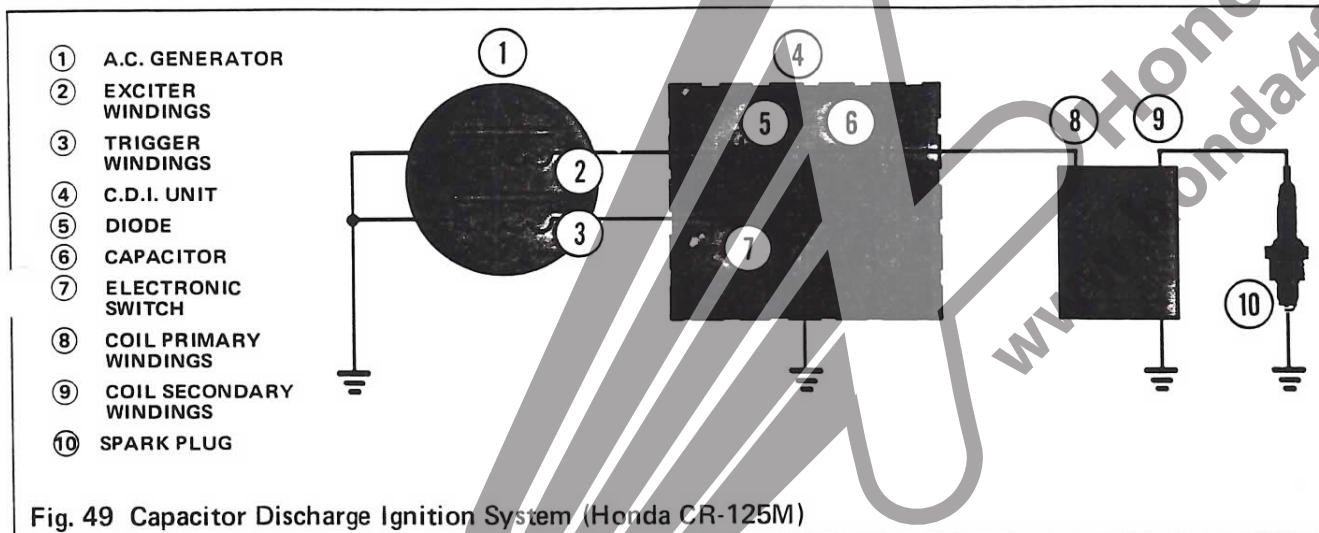

Exciter windings (2) in the generator (1) produce alternating current. The positive half of the A.C. wave (see Alternating Current Wave Form, page 10, Fig. 23) passes through the diode (5) in the C.D.I. unit (4) to charge the capacitor (6). Because the diode allows current to pass in only one direction, the capacitor is prevented from discharging through the magneto during the negative half of the magneto's A.C. wave.

Alternating current induced in the trigger windings (3) of the generator (1) are used to open and close the electronic switch (7) in the C.D.I. unit (4) (the electronic switch circuit is considerably more complicated than is shown in Fig. 49).

The electronic switch (7) (page 32) is opened while the magneto charges the capacitor. When the electronic switch closes, this completes a circuit, grounding one end of the capacitor through the switch, while the other end is grounded through the ignition coil primary windings (8). The capacitor then discharges through the ignition coil primary windings, causing the rapid build-up of a magnetic field which induces high voltage in the ignition coil secondary windings (9). High voltage induced in the secondary windings flows through the spark plug (10).

Ignition Advance:

The ignition spark must be timed to ignite the air-fuel mixture in the cylinder as the piston nears the end of its compression stroke. Timing must be precise in order to obtain maximum power and fuel economy. Optimum ignition timing is determined mainly by such factors as engine rpm, fuel quality, air-fuel mixture ratio, and combustion chamber design. Engine speed determines the time available to complete combustion in relation to piston position. Fuel quality, air-fuel mixture ratio, and combustion chamber design affect the speed with which combustion can occur.

Combustion in the engine cylinder is not instantaneous. Ignition must occur before the end of the compression stroke in order for combustion to be completed in time to drive the piston downward on the power stroke.

At idling speed, ignition can be timed to occur quite late in the compression stroke, because there is ample time for combustion to be completed as the piston starts its power stroke. At high speeds, ignition must occur earlier during the compression stroke.

If ignition occurs too early during the compression stroke, combustion will be completed before the piston reaches its top dead center position. The piston is then forced to move upward against extremely high pressure. If flywheel momentum cannot overcome the pressure against the piston, the engine will stall, or kick backward when being started. Excessive ignition advance will result in overheating and loss of power. The air-fuel mixture may also detonate with an audible knock. The piston may become damaged by overheating and detonation.

If ignition occurs too late, combustion will not be completed until the piston has travelled downward on its power stroke. This reduces the pressure which propels the piston and power is lost.

If ignition is retarded still farther, combustion may not be completed at the start of the exhaust stroke, and the air-fuel mixture will be discharged into the exhaust port while still burning intensely. This will cause overheating, and in four-stroke engines may burn the exhaust valve.

Most motorcycles are equipped with a device which automatically advances ignition timing as engine rpm increases. An automatic ignition advance (Fig. 50 & 51) is used on Honda motorcycles equipped with battery ignition systems and on some Honda models equipped with energy transfer systems.

Some motorcycles, especially mini-bikes and dirt bikes using the energy transfer system, have fixed ignition timing; no automatic advance mechanism is provided. These motorcycles have their ignition timing set permanently in an advanced position, so that timing will be most nearly correct when the engine is running at medium or high speeds.

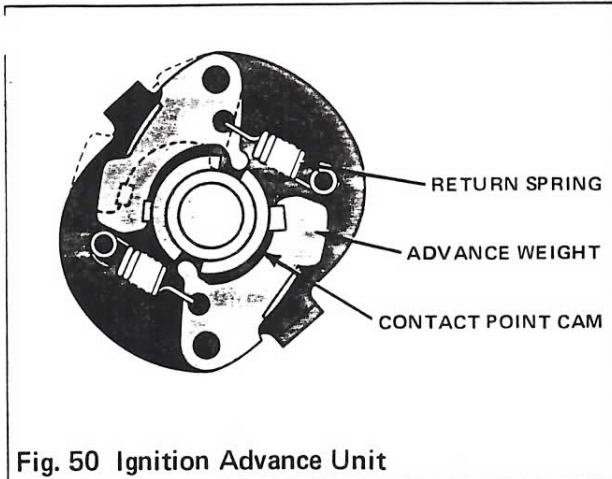

Fig. 50 Ignition Advance Unit

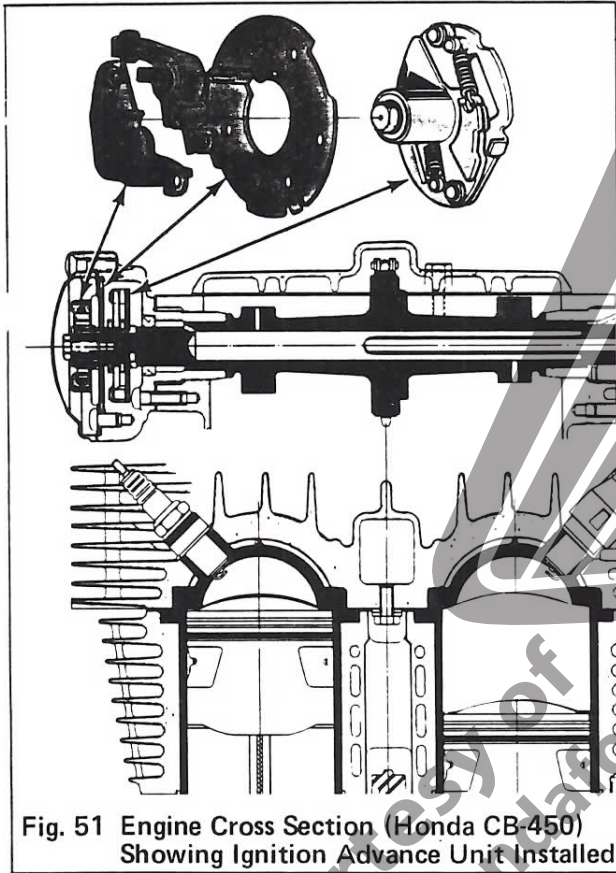

Fig. 51 Engine Cross Section (Honda CB-450)
Showing Ignition Advance Unit Installed

Centrifugal Ignition Advance Operation:

The centrifugal ignition advance unit (Fig. 50) rotates with the contact point cam and is driven by the engine camshaft or crankshaft. Fig. 51 shows an ignition advance unit installed on the end of the camshaft. Centrifugally controlled weights in the advance unit regulate the position of the contact point cam relative to the camshaft and crankshaft.

At idle speed, the weights are held inward by spring tension, and the cam is positioned to open the contact points near the end of the compression stroke (usually 5° to 15° before top dead center, depending on model design). At idle speed, there is ample time for combustion to be well underway before the piston moves down on its power stroke, and a minimal advance promotes smooth idling and prevents kick-back during starting.

As engine speed increases, the advance weights fly outward by centrifugal force, rotating the contact point cam ahead. In the advanced position, the cam opens the contact points earlier during the compression stroke (usually 25° to 45° before top dead center, depending on model design).

Capacitor discharge ignition systems do not have contact points and therefore cannot use a mechanical advance unit. Electronic ignition advance can be provided by taking advantage of the fact that increased rpm induces greater voltage in the trigger windings, which in turn controls the electronic switch that discharge the capacitor.

Dwell Angle and Contact Point Gap Adjustment:

Dwell angle (4) is the distance (measured in degrees or in percent of one full revolution) which the contact point cam (3) rotates while the contact points (1) are closed. Increasing dwell angle causes the contact points to be closed for a longer duration and open for a shorter duration. Decreasing dwell angle has the opposite result. For every ignition system design, there is a specific dwell angle range in which the system operates most effectively.

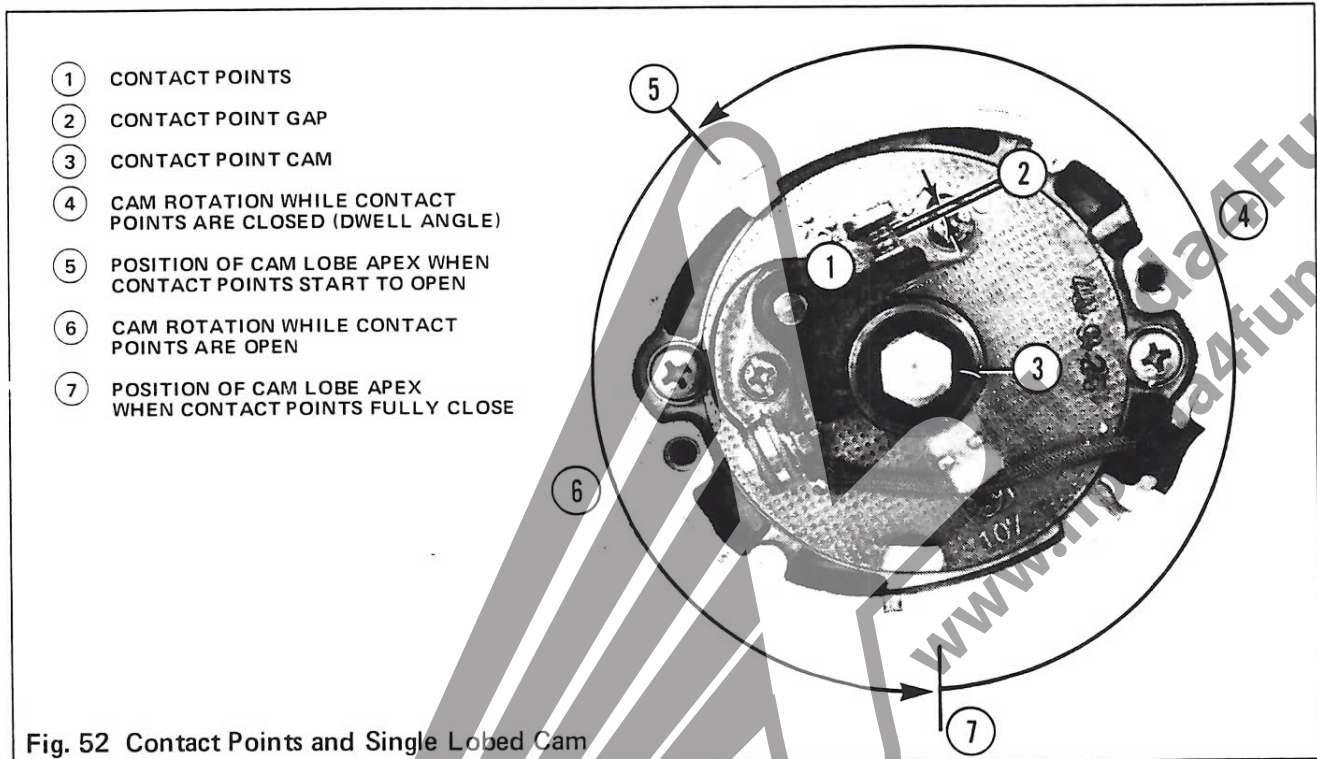

Fig. 52 Contact Points and Single Lobed Cam

Contact point gap adjustment controls dwell angle. Increasing contact point gap (2) (measured with contact points in the fully opened position) decreases dwell angle. Decreasing the gap increases dwell angle.

If possible, adjust contact point gap using a dwell meter. If you do not have a dwell meter, or if no dwell specification is available, then adjust contact point gap using a wire clearance gauge.

A wire gauge will measure contact point gap more accurately than a flat gauge, if the contact point surfaces have any irregularities due to wear or pitting. Slight wear, corrosion, or pitting can be corrected by dressing the contact points with a contact point file. Badly worn or pitted contact points should be replaced. Severe pitting indicates a faulty capacitor (condenser) which should also be replaced. While servicing the contact points, also lubricate the contact point cam with a thin film of grease.

The recommended contact point gap for Honda motorcycles is 0.3 - 0.4mm (0.012 - 0.016 in.), measured with contact points in the fully opened position. If the contact points are in good condition, this clearance will usually produce an acceptable dwell angle.

IGNITION SYSTEMS

Ignition Timing Adjustment:

Ignition timing can be adjusted by widening or narrowing the contact point gap (2), or by repositioning the contact points (1) relative to the contact point cam (3). With Honda motorcycles using capacitor discharge ignition, timing is adjusted by repositioning the magneto stator relative to the rotor.

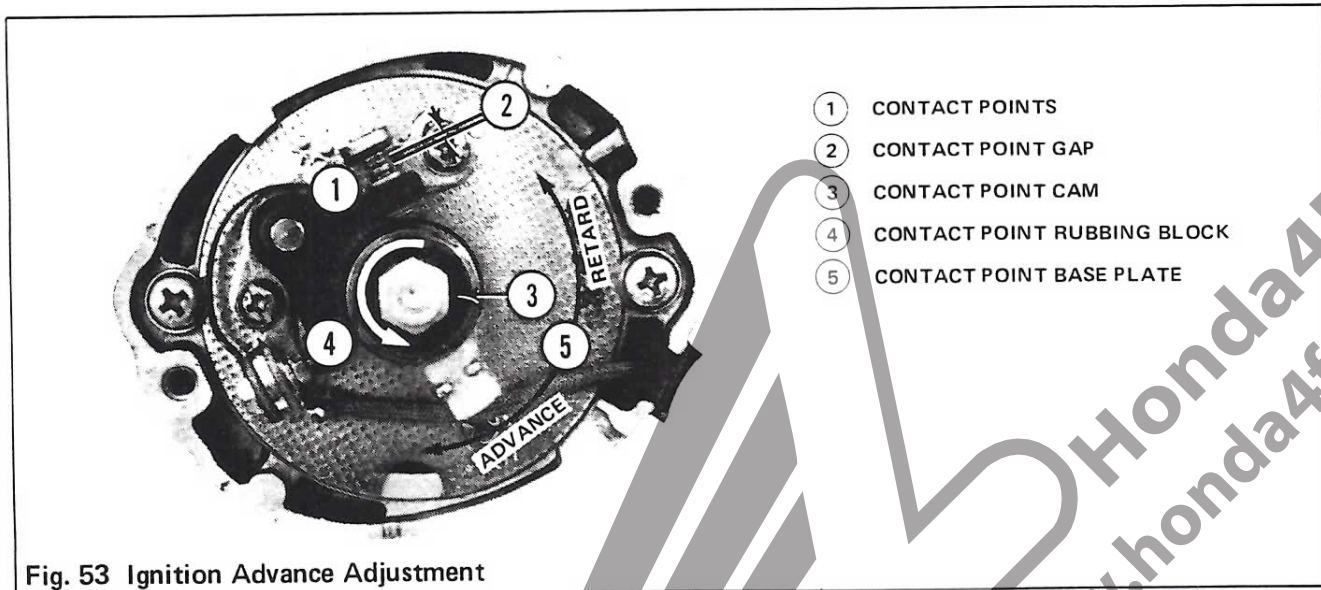

When the contact point gap (2) is widened, the cam lobe (3) contacts the rubbing block (4) earlier in its rotation (timing is advanced), and the cam lobe stays in contact with the rubbing block longer (dwell angle is decreased). Conversely, narrowing the contact point gap retards timing and increases dwell angle.

When the contact point base plate (5) is moved in the *opposite direction* of contact point cam rotation, the cam lobe (3) contacts the rubbing block (4) earlier in its rotation, and timing is advanced. Conversely, moving the contact point base plate in the *same direction* as contact point cam rotation will retard timing.

Ignition timing adjustment for some motorcycle models is accomplished solely by varying the contact point gap. For some models, adjustment is accomplished solely by moving the contact point base plate. Some other models require a combination of both procedures to adjust ignition timing.

When altering the ignition point gap for the purpose of adjusting ignition timing, do not exceed the recommended dwell angle range. If you measure contact point gap instead of dwell angle, then do not set the gap narrower than 0.3mm (0.012 in.) or wider than 0.4mm (0.016 in.). If correct ignition timing cannot be achieved within the specified dwell angle or gap range, then replace the contact points.

For greatest accuracy, use a stroboscopic timing light, so you can adjust ignition timing with the engine running (Fig. 54). On models equipped with automatic ignition advance, a stroboscopic timing light is essential for checking full advance timing.

If you do not have a stroboscopic timing light, it will be necessary to check ignition timing with the engine stopped, using a continuity light or similar device. This method is called *static timing*.

If the motorcycle has a *battery ignition system*, a simple continuity light can be connected in parallel with the contact points to check static timing. (Fig. 55). With the ignition switch and engine switch on, turn the crankshaft slowly, and the bulb will light when the contact points *open*. A continuity light can be easily constructed, using a 6 or 12 volt (depending on the motorcycle's battery voltage), 3 watt bulb or one of the bulbs from the motorcycle's instrument lights.

If the motorcycle has an *energy transfer system*, the simple continuity light shown in Fig. 55 will not work, no matter whether the motorcycle is battery equipped or not. For static timing with an energy transfer system, it is necessary to disconnect the contact point lead from the motorcycle's electrical system and connect a self-powered continuity light in series with the contact points (Fig. 56). With this hook-up, the bulb will light when the contact points *close*. A self-powered continuity light can also be used to check *battery ignition system* timing, if the contact point leads are disconnected.

Some mechanics prefer to use a buzzer rather than a light. Self-powered "buzz boxes" are commercially available for this purpose. As an inexpensive alternative, a child's toy telegraph set can be hooked-up to light, buzz, or click when the contact points close. A VOM or ohmmeter can also be used to determine when the contact points open and close.

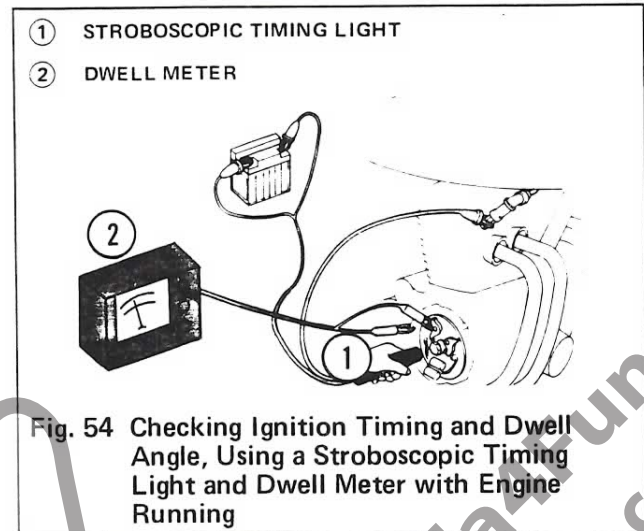

Fig. 54 Checking Ignition Timing and Dwell Angle, Using a Stroboscopic Timing Light and Dwell Meter with Engine Running

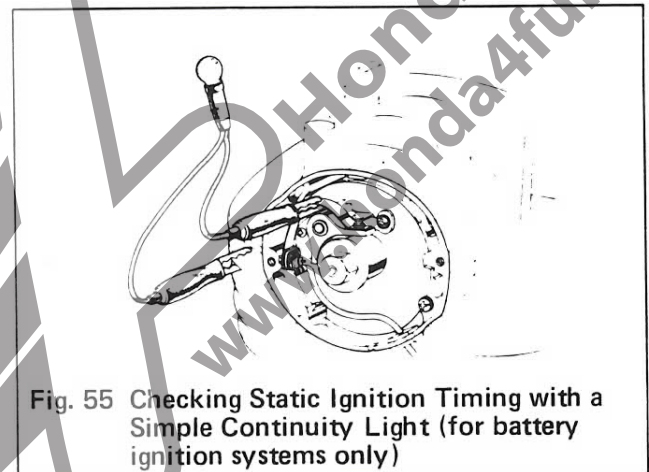

Fig. 55 Checking Static Ignition Timing with a Simple Continuity Light (for battery ignition systems only)

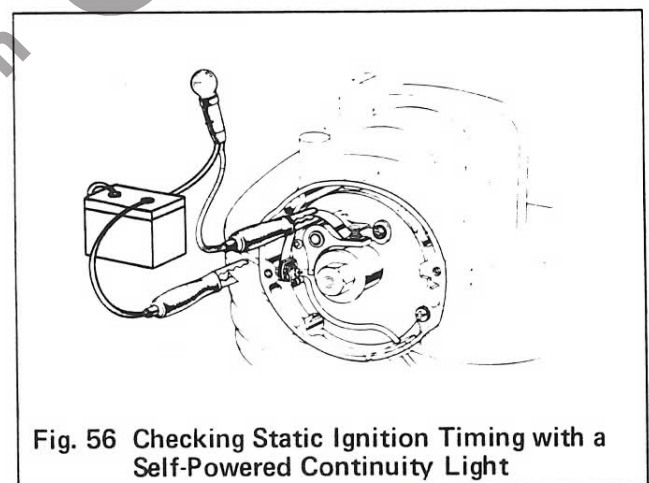

Fig. 56 Checking Static Ignition Timing with a Self-Powered Continuity Light

IGNITION SYSTEMS

Ignition Timing Marks:

Honda single cylinder and twin cylinder models have timing marks stamped on the generator rotor (see Fig. 57, 59, 61 on following pages). Honda four cylinder air-cooled models have timing marks on the ignition advance assembly (see Fig. 63, page 41). The Honda GL-1000 has timing marks on the edge of the flywheel (see Fig. 65, page 42).

Timing marks are lettered "T" for *top* dead center piston position and "F" for ignition *firing* position at idle speed. The "F" mark is also used to indicate the static timing position. All Honda motorcycle engines equipped with automatic ignition advance have additional marks which indicate ignition full advance position (see Fig. 57, 59, 61, 63, 65 on following pages).

Twin cylinder engines with 180° crankshafts (e.g. CB-360T, CB-500T) have two sets of timing marks. Timing marks for the right cylinder (as viewed from the rider's position) are designated "T" and "F", while timing marks for the left cylinder are designated "LT" and "LF".

Four cylinder air-cooled engines have two sets of timing marks, "T, F, 1-4" and "T, F, 2-3", which are referenced to cylinder numbers and contact point assemblies. The GL-1000 has two sets of timing marks, "1-T-F" and "2-T-F", which are referenced to contact point assemblies only and not to cylinder numbers.

Procedure for Adjusting Contact Point Gap and Ignition Timing on Honda Single Cylinder Engines Without Adjustable Contact Point Base Plate:

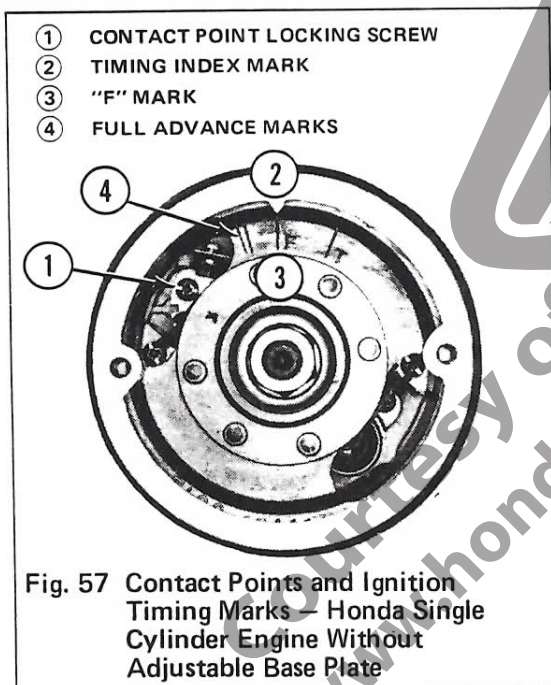

1. Check ignition timing. If adjustment is required, loosen contact point locking screw ① (Fig. 57). Adjust contact point gap to achieve correct timing. Retighten locking screw. Recheck timing after locking screw is tightened.

Idle or static timing is correct if contact points open when index mark ② aligns with rotor "F" mark ③. Most Honda models without an adjustable base plate also have no automatic ignition advance mechanism, and the "F" mark is used for timing at any rpm. If the motorcycle *does* have an automatic ignition advance mechanism, high rpm timing is correct if contact points open when index mark ② is between full advance marks ④.

NOTE: Full advance timing is more important to performance than idle timing. If the motorcycle is equipped with an automatic ignition advance, adjust

contact point gap to achieve correct full advance timing for best results. If correct full advance timing causes idle timing to be substantially incorrect, then replace the ignition advance mechanism.

2. Check dwell angle or contact point gap (see page 35). If dwell angle is not within limits specified in the shop manual, or if contact point gap is not within a range of 0.3 - 0.4mm (0.012 - 0.016 in.), then replace the contact points and repeat step one.

Procedure for Adjusting Contact Point Gap and Ignition Timing on Honda Single and Twin Cylinder Engines Having One Set of Contact Points and an Adjustable Contact Point Base Plate:

1. Check dwell angle or contact point gap. If adjustment is required, loosen contact point locking screws (1) (Fig. 58). Adjust contact point gap to achieve the dwell angle specified in the shop manual, or adjust gap to 0.3 - 0.4mm (0.012 - 0.016 in.). Tighten locking screws. Recheck dwell angle or gap after locking screws are tightened.
2. Check ignition timing. If adjustment is required, loosen base plate locking screws (2). Rotate base plate to achieve correct ignition timing. Tighten locking screws. Recheck dwell angle or gap, and timing, after locking screws are tightened.

Idle or static timing is correct if contact points open when index mark (3) (Fig. 59) aligns with rotor "F" mark (4). High rpm timing is correct if contact points open when index mark (3) is between full advance marks (5).

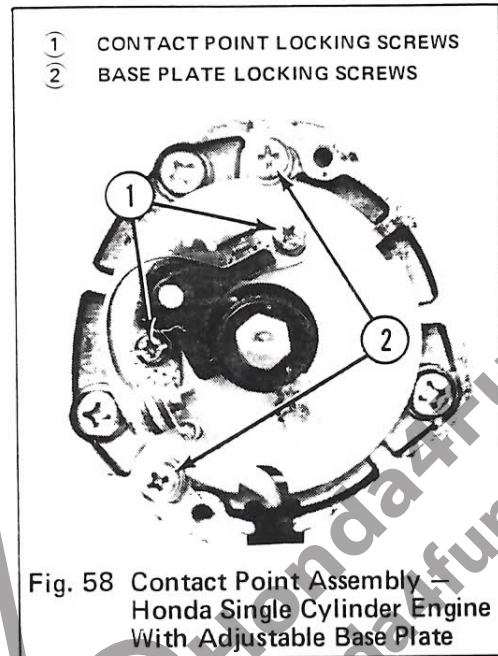

Fig. 58 Contact Point Assembly - Honda Single Cylinder Engine With Adjustable Base Plate

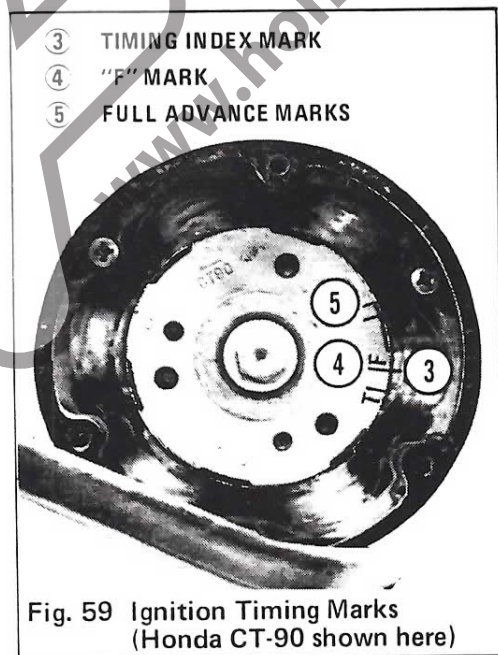
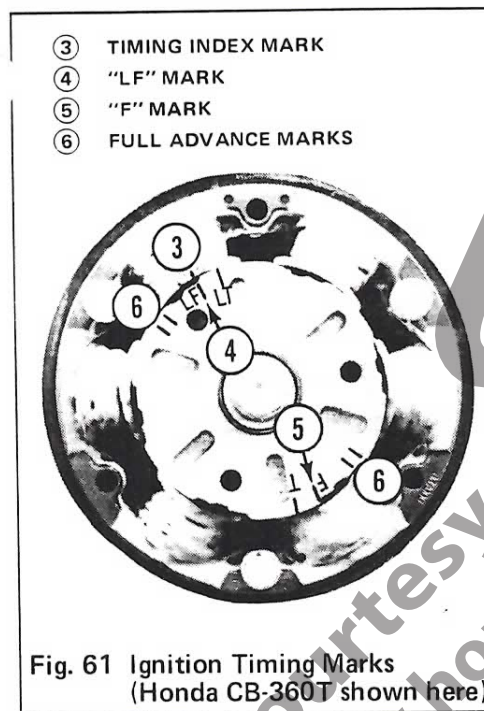
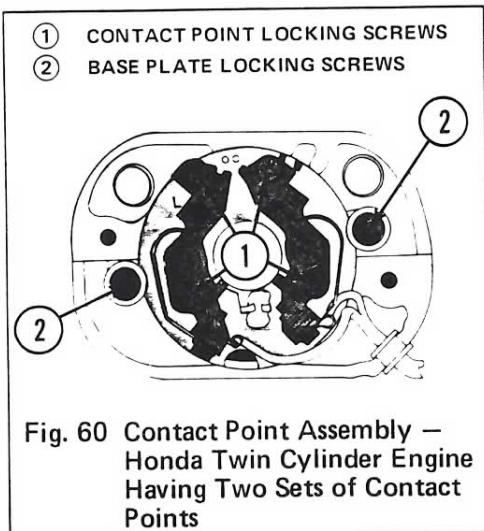

Fig. 59 Ignition Timing Marks (Honda CT-90 shown here)

IGNITION SYSTEMS

Procedure for Adjusting Contact Point Gap and Ignition Timing on Honda Twin Cylinder Engines Having Two Sets of Contact Points:



1. Check dwell angle or contact point gap. If adjustment is required, loosen contact point locking screws ①, (Fig. 60). Adjust both left and right contact point gaps to achieve the dwell angle specified in the shop manual, or adjust gap to 0.3 - 0.4mm (0.012 - 0.016 in.). Tighten locking screws. Recheck dwell angle or gap after locking screws are tightened.
2. Check both left and right cylinder ignition timing. Left cylinder idle or static timing is correct if the left contact points open when index mark ③ (Fig. 61) aligns with rotor "LF" mark ④. Right cylinder timing is correct if the right contact points open when index mark ③ aligns with rotor "F" mark ⑤. High rpm timing is correct if left and right contact points open when index mark ③ is between the full advance marks ⑥.
3. If *both* left and right contact points open before or after the timing marks align, loosen the base plate locking screws ② (Fig. 60), and rotate the base plate to achieve correct timing. Retighten the base plate locking screws. Recheck dwell angle or gap, and timing, after locking screws are tightened.
4. If *only one* set of contact points is not correctly timed, re-adjust contact point gap to synchronize the timing for both cylinders. Increase gap to advance timing or decrease gap to retard timing. Contact point gap must not exceed the specified dwell angle or gap range. If correct ignition timing cannot be achieved within the specified dwell angle or gap range, replace the contact points.

Procedure for Adjusting Contact Point Gap and Ignition Timing on Honda Four Cylinder Air-Cooled Engines:

1. Check dwell angle or contact point gap. If adjustment is required, loosen contact point locking screws (1) (Fig. 62). Adjust both #1/#4 and #2/#3 contact point gaps to achieve the dwell angle specified in the shop manual, or adjust gap to 0.3 - 0.4mm (0.012 - 0.016 in.). Tighten locking screws. Recheck dwell angle or gap after locking screws are tightened.

2. Check ignition timing for #1/#4 cylinders (cylinders are numbered from left to right as viewed from the rider's position). If adjustment is required, loosen main base plate locking screws (2). Rotate main base plate to achieve correct timing. Tighten locking screws. Recheck dwell angle or gap, and timing, after locking screws are tightened.

Idle or static timing for #1/#4 cylinders is correct if #1/#4 (left) contact points open when index mark (4) (Fig. 64) aligns with "F 1•4" mark (5). High rpm timing is correct if left contact points open when index mark (4) is between #1/#4 full advance marks (6).

3. Check ignition timing for #2/#3 cylinders. If adjustment is required, loosen #2/#3 base plate locking screws (3). Rotate #2/#3 base plate to achieve correct ignition timing. Tighten locking screws. Recheck #2/#3 dwell angle or gap, and timing, after locking screws are tightened.

Idle or static timing for #2/#3 cylinders is correct if #2/#3 (right) contact points open when index mark (4) aligns with "F 2•3" mark (not illustrated). High rpm timing is correct if right contact points open when index mark (4) is between #2/#3 full advance marks.

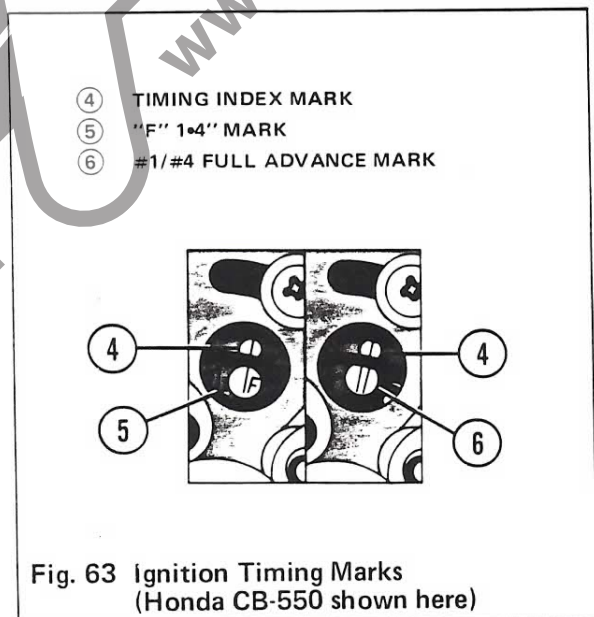
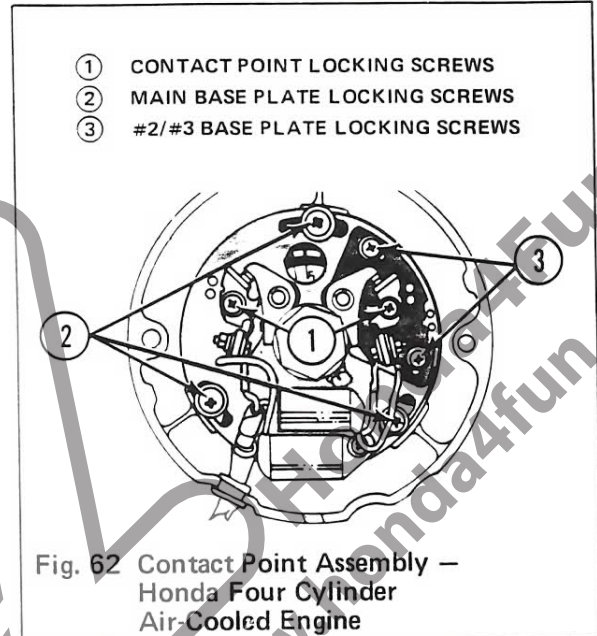

IGNITION SYSTEMS

Procedure for Adjusting Contact Point Gap and Ignition Timing on the Honda GL-1000:

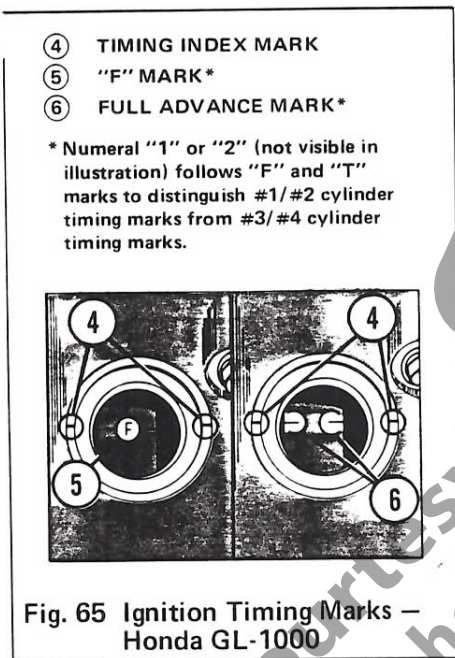
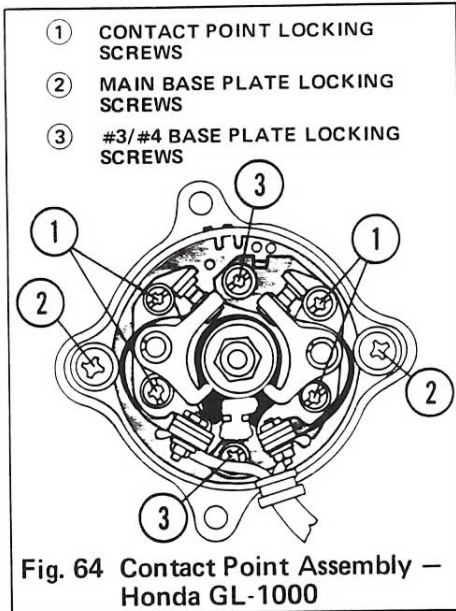

1. Check dwell angle or contact point gap. If adjustment is required, loosen contact point locking screws ① (Fig. 64). Adjust both contact point gaps to achieve the dwell angle specified in the shop manual, or adjust gap to 0.3 - 0.4mm (0.012 - 0.016 in.). Tighten locking screws. Recheck dwell angle or gap after locking screws are tightened.

2. Check ignition timing for #1/#2 cylinders (cylinders are numbered as follows: #1 = right front; #2 = left front; #3 = right rear; #4 = left rear). If adjustment is required, loosen main base plate locking screws ②. Rotate main base plate to achieve correct ignition timing. Tighten locking screws. Recheck dwell angle or gap, and timing, after locking screws are tightened.

Idle or static timing for #1/#2 cylinders is correct if #1/#2 (left) contact points open when index mark ④ (Fig. 65) aligns with "1-F" mark ⑤. High rpm timing is correct if left contact points open when index mark ④ aligns with full advance mark ⑥.

3. Check ignition timing for #3/#4 cylinders. If adjustment is required, loosen #3/#4 base plate locking screws ③. Rotate #3/#4 base plate to achieve correct ignition timing. Tighten locking screws. Recheck #3/#4 dwell angle or gap, and timing, after locking screws are tightened.

Idle or static timing for #3/#4 cylinders is correct if #3/#4 (right) contact points open when index mark ④ aligns with "2-F" mark ⑤. High rpm timing is correct if right contact points open when index mark ④ aligns with full advance mark ⑥.

Spark Plugs:

Fig. 66 shows the cross section of a typical spark plug. The spark plug provides an electrode gap inside the combustion chamber where a spark will ignite the air-fuel mixture. The insulator (2) is sealed to the center electrode (3) and shell (4) to prevent the escape of combustion gases through the spark plug. A gasket (5) under the shoulder of the shell prevents the escape of combustion gases between the spark plug and cylinder head.

Spark plugs are manufactured in standard sizes which are classified in terms of thread diameter (9) and reach (6) (Fig. 66 & 67). *Reach* is the distance from the shoulder of the shell to its threaded end. Gasket thickness is not included in the reach measurement. These spark plug dimensions must match the corresponding cylinder head dimensions of the motorcycle. For example, a Honda CB-750 requires spark plugs with a 12mm thread diameter and 19mm ($\frac{3}{4}$ in.) reach. Various Honda models use spark plugs of 10mm, 12mm, or 14mm thread diameter and 12.7mm ($\frac{1}{2}$ in.) or 19mm ($\frac{3}{4}$ in.) reach.

If the spark plug does not have the correct thread diameter, then obviously it cannot be installed. If the reach is too long, the spark plug will protrude into the combustion chamber where it may overheat, possibly interfere with piston or valve movement, and carbon deposits will accumulate on spark plug threads making removal difficult. If the reach is too short, the spark will occur in the cavity of the spark plug well where it will be less effective, and carbon deposits will accumulate on cylinder head threads impeding installation of the correct reach.

The service life of a spark plug varies with factors of operating conditions, type and grade of fuel, compression ratio, etc. Spark plugs should be inspected, cleaned and regapped, or replaced, in accordance with the maintenance schedule in the owner's manual.

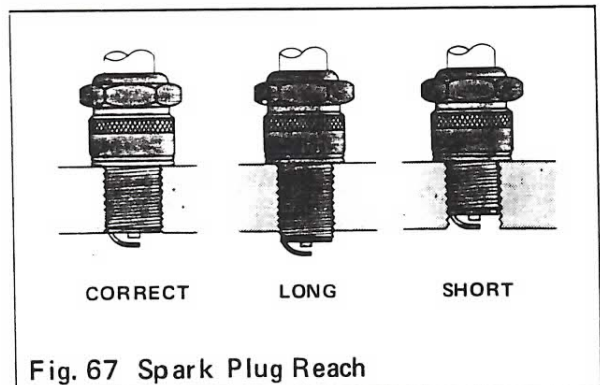
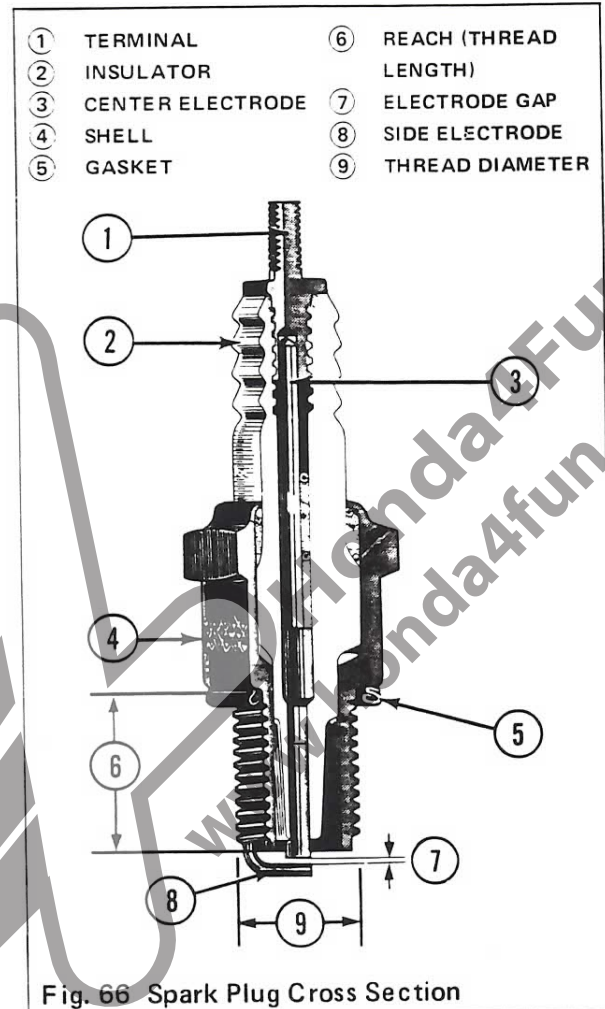

IGNITION SYSTEMS

The gap (7) between center electrode (3) and side electrode (8) (Fig. 66, page 43) must be wide enough to produce a good spark, but not so wide that the ignition coil cannot produce enough voltage to jump the gap. The gap widens with use due to electrode erosion from heat and chemical action. Spark plug voltage requirements increase as the gap widens.

Carbon and chemical deposits on the insulator nose also increase voltage requirements. These deposits conduct electricity and allow some of the current to leak across the insulator nose instead of jumping the electrode gap. Electrode wear and deposits on the insulator nose eventually raise voltage requirements to a point where the ignition coil has an insufficient voltage reserve, resulting in loss of spark intensity, and ultimately causing misfiring.

Spark plugs with high mileage may also develop insulator cracks or gas leakage between the insulator and shell. Regapping and cleaning will help to extend spark plug service life, but the plugs must eventually be replaced.

Before removing a spark plug, clean the area around the base of the plug to prevent dirt or debris from falling into the combustion chamber through the open spark plug well. Inspect the spark plug for excessive electrode wear, insulator cracks, or signs of gas leakage (gray stains on the outside of the insulator near the top of the shell). If these conditions are found to exist, discard the spark plug. Inspect the insulator nose and electrodes for signs of fouling or overheating (see Spark Plug Heat Range, page 45). If the spark plug appears to be reusable, clean and regap the plug.

Commercial sandblast spark plug cleaners remove fouling deposits quite well. If you do not have access to such a device, it is possible to achieve some improvement by picking off encrusted deposits and cleaning the spark plug with solvent and a rag. Also wipe clean the exterior of the spark plug insulator and interior of the spark plug cap to reduce the possibility of electrical flashover.

Use a wire gauge to measure spark plug electrode gap. Where there are any surface irregularities, a wire gauge will measure more accurately than a flat gauge. Electrode gap specifications are given in the owner's manuals and shop manuals for each Honda model. All spark plugs, whether new or used, should be accurately gapped before installation. Electrode gap is adjusted by carefully bending the side electrode.

Install spark plugs finger-tight, then use a spark plug wrench for final tightening. The initial placement of the spark plug is done without using the force of a wrench in order to prevent the possibility of cross-threading and damaging the cylinder head threads.

Optimum spark plug tightening torque varies with such factors as cylinder head thread material (iron or aluminum), the condition of the cylinder head threads, and whether they are clean or dirty, dry or oily. Spark plug tightening torque specifications may be found in some Honda shop manuals and in some literature published by spark plug manufacturers, though specifications from different sources will not necessarily coincide. Few people use a torque wrench to install spark plugs anyway.

Spark plugs must be tightened firmly enough to compress the gasket and form a gastight seal, but over-tightening may cause cylinder head thread damage. The spark plug gasket can be reused several times, provided it remains with the same spark plug and cylinder with which it was originally used.

Spark Plug Heat Range:

Heat range refers to the spark plug's ability to transfer heat from the center electrode's firing tip, through the insulator, through the spark plug shell, to the cylinder head where heat is dissipated (Fig. 68). The ability of the spark plug to transfer heat is controlled by the exposed length of the insulator nose (Fig. 69). When the exposed insulator nose is relatively long, heat from the center electrode's firing tip must travel a relatively long path to reach the spark plug shell and cylinder head. Conversely, when the exposed insulator nose is shorter, heat has a shorter path to follow and is dissipated more easily.

Spark plug manufacturers produce each spark plug size and model in many heat ranges, using carefully graduated differences in the length of the exposed insulator nose.

The operating temperature of a spark plug varies in relation to exposed insulator nose length and also with all factors which affect combustion chamber temperature, such as engine design, engine rpm and load, riding conditions, air-fuel mixture ratios, ignition timing, etc. Fouling is likely to occur when the temperature of the center electrode's firing tip is less than approximately 450°C (842°F). Preignition is likely to occur when the temperature of the center electrode's firing tip exceeds approximately 950°C (1742°F).

The objective of spark plug heat range selection is to equip the engine with spark plugs which will maintain electrode and insulator tip temperatures hot enough to burn off carbon and chemical deposits that cause fouling, yet cool enough to prevent preignition.

Preignition takes place when a hot spot in the combustion chamber (such as a glowing hot spark plug electrode) ignites the air-fuel mixture before the ignition spark occurs. Preignition greatly increases combustion chamber heat and pressure which may burn or melt the spark plug firing tip. Worse yet, preignition may cause serious engine damage, such as seized or holed pistons. Therefore, it is safest to select the coldest spark plug (shortest exposed insulator nose length) that will function without fouling.

Whenever spark plugs are removed from the engine, note the appearance of the insulator tip and electrodes. An abnormal appearance may indicate the need for engine service or spark plugs of a different heat range. Most spark plug manufacturers publish literature with full color photographic illustrations of various spark

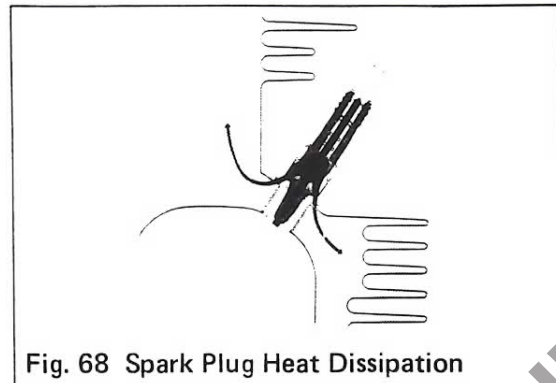

Fig. 68 Spark Plug Heat Dissipation



Fig. 69 Spark Plug Insulator Nose Length and Heat Range

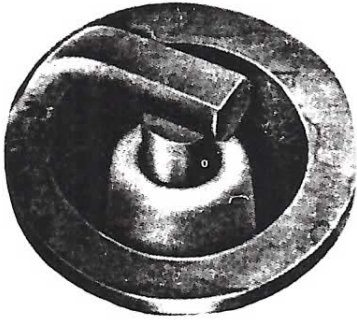

Fig. 70 Normal Spark Plug Firing Tip



Fig. 71 Overheated Spark Plug Firing Tip



Fig. 72 Fouled Spark Plug Firing Tip

plug conditions. Obtain a copy of such literature, if available. Full color photographic illustrations are a far better diagnostic guide than Fig. 70, 71, 72 of this manual.

The insulator color of a normal spark plug (Fig. 70) will be brown, tan, or yellow (shades of gray if unleaded fuel is used). Electrode wear will be proportionate to the mileage the spark plug has been used. Normal coloration and wear indicate that the engine is functioning properly and the spark plug is of suitable heat range.

Insulator color will become chalk white as the spark plug starts to overheat. Extreme overheating (Fig. 71) will produce a blistered insulator appearance with melted deposits, and the electrodes will become abnormally eroded or even melted.

A spark plug may become overheated from any of the following conditions:

- Excessively advanced ignition timing.
- Lean air-fuel mixture ratio or intake air leak.
- Detonation (inadequate fuel octane rating or lugging the engine).
- Preignition (hot spots in the combustion chamber).
- Insufficient engine cooling (no air flow over cooling fins or loss of liquid coolant).
- Spark plug heat range too high for operating conditions.

The insulator nose and electrodes will become black and fouled (Fig. 72) if spark plug operating temperature is too low to burn off carbon deposits, or if fuel or oil in the combustion chamber cause excessive carbon deposits.

Dry, sooty fouling may be caused by any of the following conditions:

- Excessive use of the choke.
- Prolonged idling or low rpm operation.
- Excessively rich air-fuel mixture ratio.
- Ignition malfunction (insufficient firing voltage).
- Spark plug heat range too low for operating conditions.

Wet, oily black fouling indicates engine wear or damage (worn valve guides, worn piston rings, damaged pistons), or excessive oil in the fuel-oil mixture of two-stroke engines.

The electric starting system uses a direct current motor to transform the battery's electrical energy into the mechanical energy needed to crank the engine. Amperage requirements are relatively high, so an electromagnetic switch and heavy gauge electrical leads are used to make the connection between battery and starter motor. When the starter motor is actuated, it drives an overrunning starter clutch that directly or indirectly (depending on Honda model) engages the engine crankshaft. Reduction gears are used between the starter motor and starter clutch to multiply the starter motor's torque.

D.C. Motor Operating Principle:

When an electric current flows through a wire, magnetic lines of force encircle the wire (see Fig. 12, page 7). If the current carrying wire is placed between the north and south poles of magnets (Fig. 73), a reaction occurs between the magnetic field encircling the wire and the magnetic field between the magnets.

If the directions of the magnetic fields are as indicated in Fig. 73, then these fields will reinforce each other below the wire where they run in the same direction, and will cancel each other out above the wire where they run in opposite directions. Consequently, the wire will be pushed upward (Fig. 74). The current carrying wire is always pushed away from the side where the resultant magnetic field is strongest.

If the electrical current through the wire were reversed, then the magnetic field would encircle the wire in the opposite direction and would react with the field between the two magnetic poles to push the wire downward.

When a loop of current carrying wire is placed between the north and south poles of magnets (Fig. 75), the direction of current flow (and consequently the direction of the magnetic field encircling the wire) in one side of the loop (A) is opposite to the direction of current flow in the other side of the loop (B). Side (A) is forced downward, side (B) is forced upward, and the loop will rotate until it stands perpendicular to the lines of magnetic force between the magnet poles, as indicated in Fig. 75 by the white loop shown at right angles to the black loop.

Rotation would stop at the point where (A) is forced downward as far as it can go, and (B) is forced to its upward limit (white loop in Fig. 75), but if the direction of current flow is quickly reversed (before the loop loses its momentum and comes

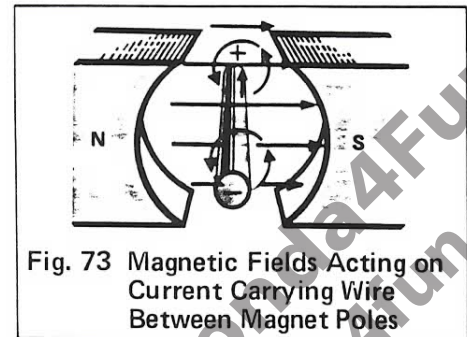

Fig. 73 Magnetic Fields Acting on Current Carrying Wire Between Magnet Poles

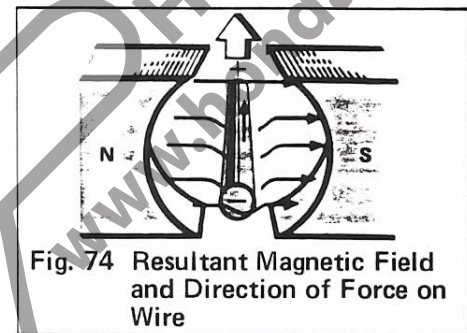

Fig. 74 Resultant Magnetic Field and Direction of Force on Wire

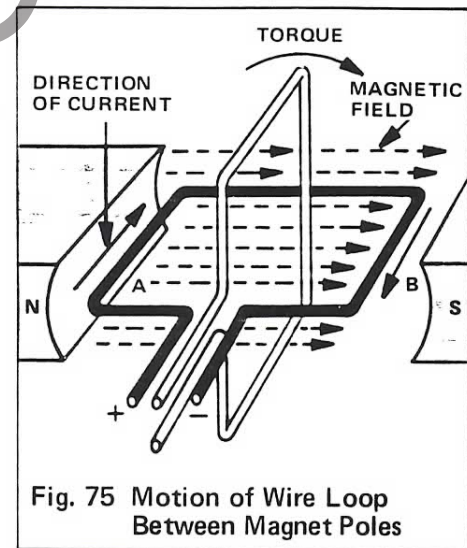
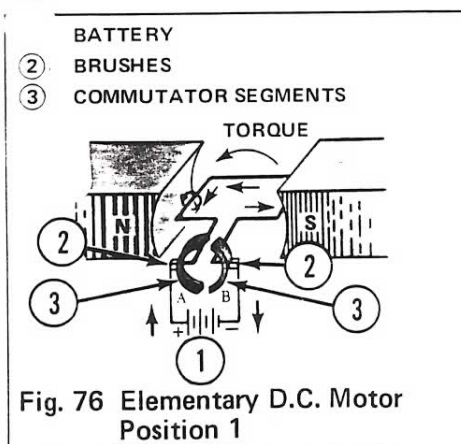

Fig. 75 Motion of Wire Loop Between Magnet Poles

ELECTRIC STARTER SYSTEM



to a complete stop), the loop will rotate another 180°. To achieve continuous rotation, it is necessary to provide a means for reversing current flow whenever the wire loop reaches the position where it is about to stop.

Reversal of current flow is accomplished by a commutator and brush arrangement (Fig. 76 - 79). The battery (1) (Fig. 76) is connected to carbon "brushes" (2) which slide against commutator segments (3) connected to the ends of the wire loop. The commutator segments rotate with the wire loop, and as they turn, each brush slides from one commutator segment to the next. The direction of current flowing through the wire loop is automatically reversed when the brushes contact opposite commutator segments, and the loop will continue to rotate as long as the battery supplies current to the brushes.

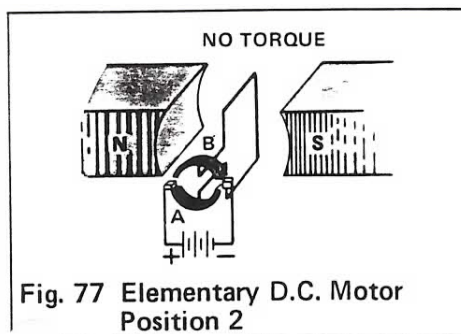

In Fig. 76, the wire loop is connected to the battery in the same polarity as in Fig. 75 (page 47). Side (A) is forced down, side (B) is forced up, and the wire loop rotates to the position shown in Fig. 77.

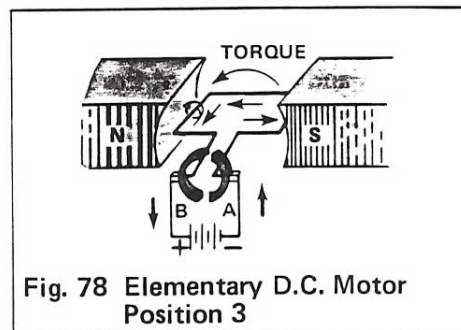

Electrical contact between the wire loop and the battery is broken as the loop coasts through the position shown in Fig. 77. No magnetic force drives the loop until the brushes establish contact with the opposite commutator segments. Torque increases as the loop fully enters the field between magnet poles (Fig. 78).

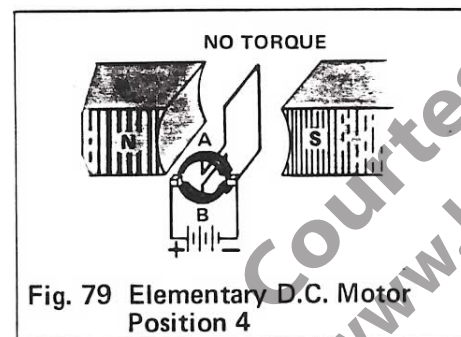

In Fig. 78, sides (A) and (B) have rotated 180°. Now side (B) is forced down, side (A) is forced up, and the wire loop rotates to the position shown in Fig. 79.

The D.C. motor shown in Fig. 76 - 79 has been greatly simplified to illustrate the basic principles. In an actual D.C. motor, additional loops of wire (*armature windings*) are used to make the motor run more smoothly and develop more power. Also, a Honda starter motor uses four electromagnets (see page 7) rather than the permanent magnets shown here.

Starter Motor Construction:

A cutaway view of a Honda starter motor is shown in Fig. 80. A diagrammatic view of the same motor is shown in Fig. 81.

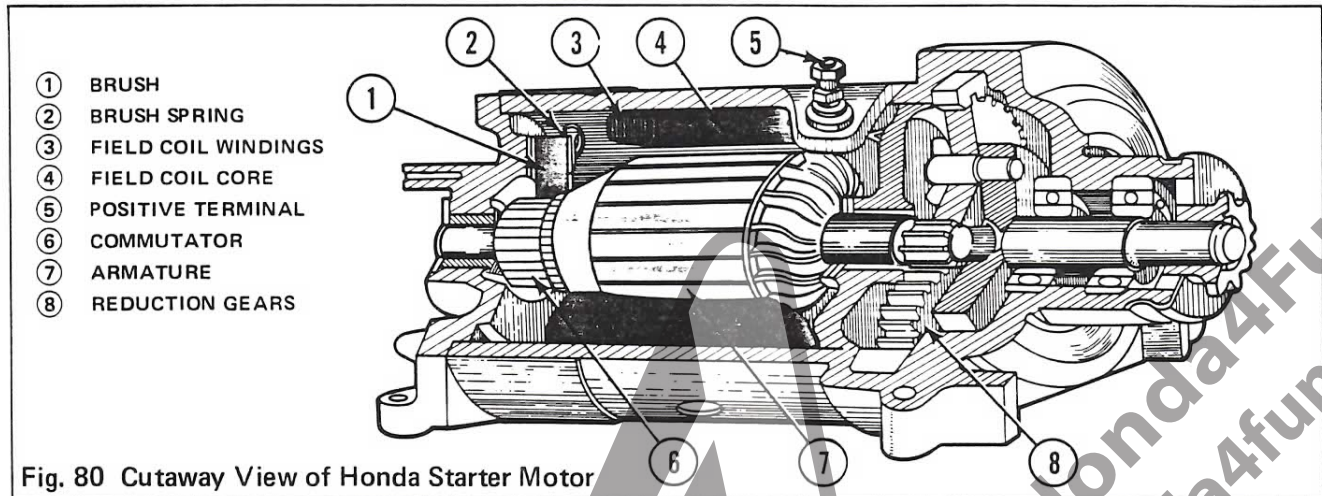

Fig. 80 Cutaway View of Honda Starter Motor

The torque of a motor containing only a single armature winding (Fig. 76 - 79) is neither continuous nor very effective. A practical starter motor (Fig. 80) contains a large number of wire coils wound around a laminated iron armature core. At one end of the armature (7), there are a number of copper commutator segments (6), corresponding to the number of armature coils. The commutator segments are insulated from each other by pieces of mica. The armature coils are so spaced that, for any position of the armature, there will be coils near the poles of the field magnets (4). This makes the torque both continuous and strong. Electromagnets (3) (4) are used in the starter motor because they can be made to furnish a stronger field than the permanent magnets shown in Fig. 76 - 79.

The brushes (1) are blocks of graphitic carbon, which have long service life and cause minimum commutator wear. Springs (2) are used to hold the brushes firmly against the commutator (6).

The brushes (1) and commutator (6) connect the field coil windings (3) with the armature (7) windings in series (Fig. 81). Any increase in current therefore strengthens the magnetism of both the field and armature. A series D.C. motor produces high starting torque, which is necessary in a starter motor. Relatively thick wire is used to keep resistance low, enabling the motor to draw large amperage.

The armature shaft is connected to reduction gears (8) which multiply the motor's torque, enabling it to crank the engine. Reduction gears may be contained in the engine crankcase or built into the starter motor housing, depending on Honda model. Fig. 80 shows a planetary gear set (8) within the starter motor housing.

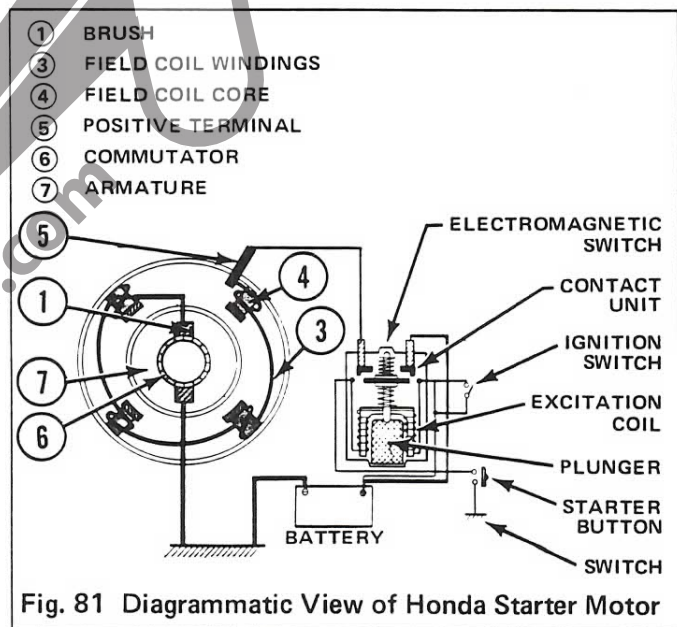
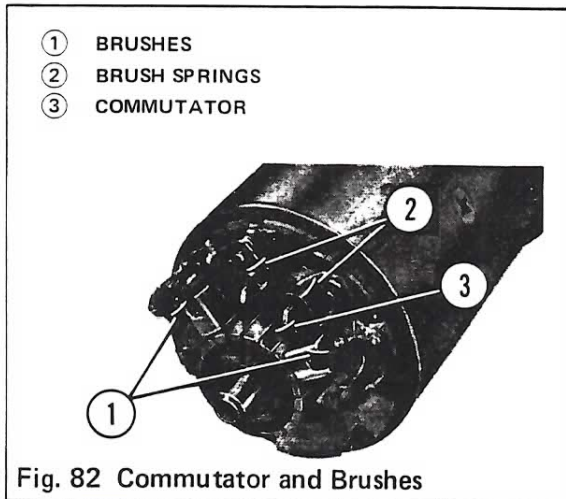

Fig. 81 Diagrammatic View of Honda Starter Motor

ELECTRIC STARTER SYSTEM

Starter Motor Service:

Brushes and commutator segments are the only parts which wear significantly in normal use and are the only parts which the mechanic can service. Replacement armatures and field coils are not available for Honda starter motors, so if malfunctions occur in those areas, the entire starter motor must be replaced.



Inspect carbon brushes ① (Fig. 82), and replace if worn to the limit of their travel within the brush holders, or refer to the shop manual for service limits in terms of brush length. Check brush springs ②, and replace if weak or broken. Refer to the shop manual for spring tension service limits.

Inspect the commutator ③. The commutator surface should be clean and copper segments ④ smooth. Mica insulation ⑤ must be slightly undercut, as shown in Fig. 83. When copper segments become worn, they will no longer stand above the mica insulation, and the brushes may not obtain good contact. Mica undercutting can be performed with a thin saw blade or small file. Rough or irregular surfaces on copper segments can be filed smooth. The use of sandpaper or emery cloth is not recommended, as abrasive particles may become imbedded in the commutator segments. Wipe the commutator clean before reassembly.

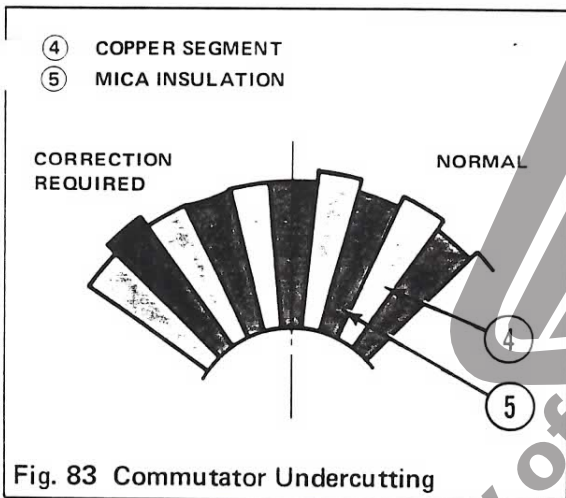

Continuity tests can be performed to determine whether a malfunction in the starter motor is due to short circuits or open circuits in the armature or field coils, and test procedures are shown in some shop manuals. However, faulty armatures or field coils in Honda starter motors can be corrected only by replacing the entire starter motor.

Continuity testing can be done with a VOM, ohmmeter, or a battery powered continuity tester of the same sort used to check static ignition timing (see page 37). Test results, indicating continuity or no continuity, should correspond logically with the circuit shown in Fig. 81 (page 49). Other results indicate faulty connections, or a faulty armature or field coils.

Electromagnetic Starter Switch:

The starter motor draws about 120 amperes of current when cranking the engine. Heavy electrical cable and a heavy-duty switch are required to properly handle the current. It would not be practical to run heavy cables up to the handlebar and install a large, heavy-duty switch there. Instead, a small push button switch on the handlebar activates an electromagnetic starter switch (Fig. 84) that connects the battery to the starter motor. The electromagnetic starter switch is mounted on the motorcycle frame, near the battery.

When the main switch (1) (Fig. 84) is turned on, and the starter button (2) is depressed, current flows from the battery (6) through an electromagnet (3) within the starter switch. The electromagnet draws the plunger (4) into contact with the terminals (5) of the starter switch, completing a circuit between the battery (6) and starter motor (7).

The electromagnetic starter switch is not ordinarily repairable and should be replaced if it malfunctions.

If the starter motor does not actuate when the push button on the handlebar is depressed, the most frequent cause is simply a discharged battery. If the battery is somewhat less than completely discharged, the switch will at least produce an audible click as the plunger moves within the electromagnet.

If the battery is well charged, and the starter motor will still not actuate when the push button on the handlebar is depressed, the electromagnetic switch can be bypassed by short circuiting the switch terminals with a screwdriver blade or other implement. If bypassing the switch actuates the starter motor, the problem is in the switch itself, or in the circuit which leads to the switch's electromagnet. If the starter motor does *not* actuate when the switch is bypassed, this indicates that the malfunction may be in the starter motor.

If the starter motor continues to run after the push button on the handlebar is released, the problem is usually due to a stuck plunger in the electromagnetic switch. If this malfunction should occur, immediately turn the main switch off, then disconnect the starter motor or battery cable. The starter motor may become seriously damaged, if the engine starts, and the starter motor runs continuously at high rpm.

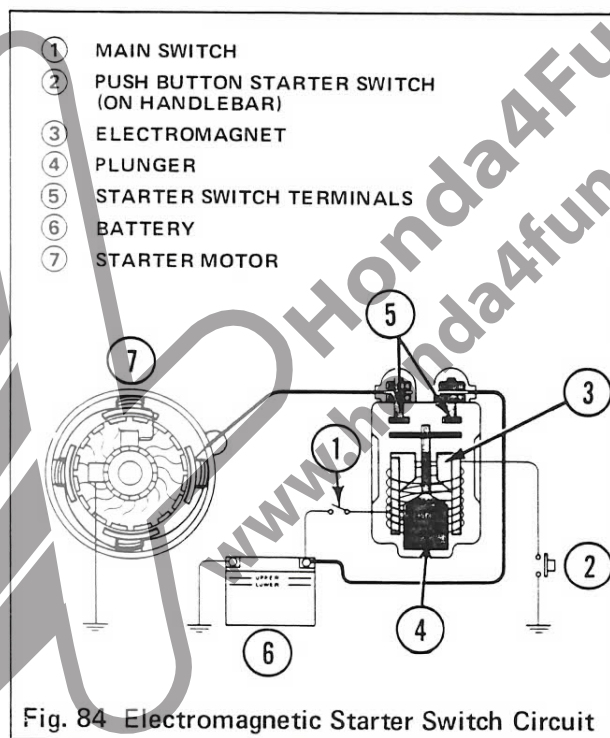

ELECTRIC STARTER SYSTEM

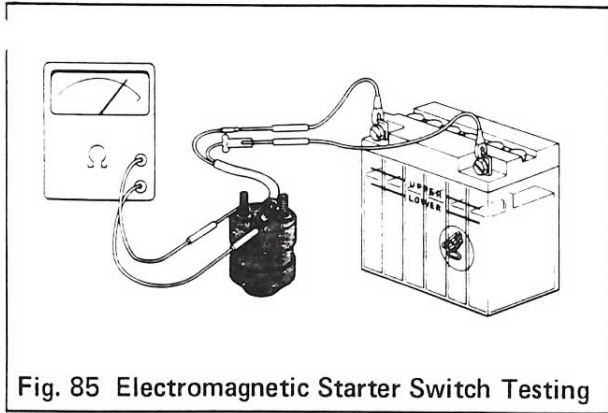

Fig. 85 Electromagnetic Starter Switch Testing

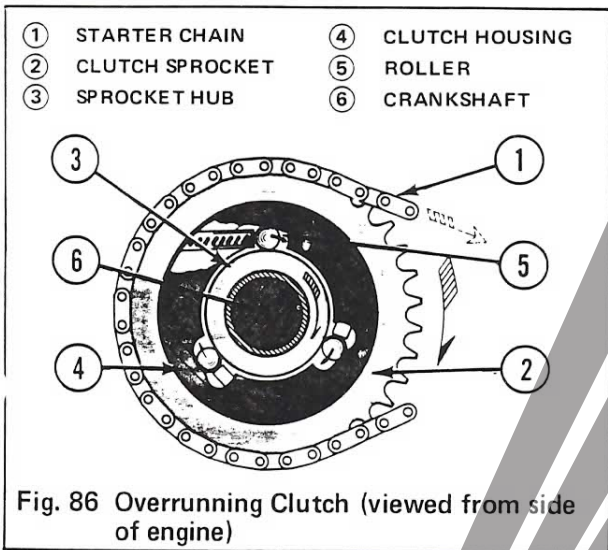

Fig. 86 Overrunning Clutch (viewed from side of engine)

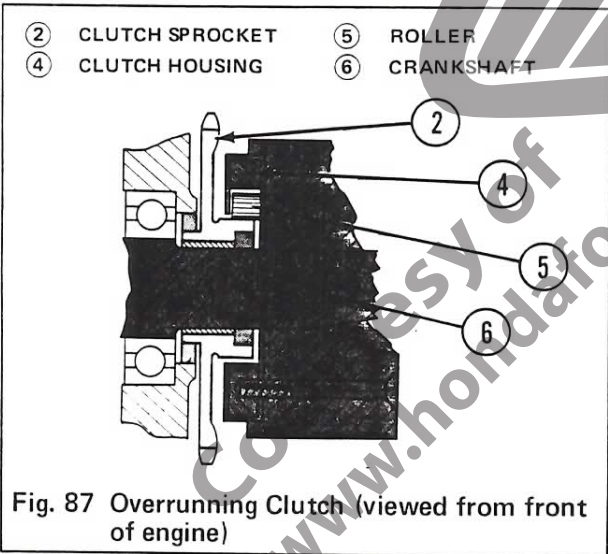

Fig. 87 Overrunning Clutch (viewed from front of engine)

Electromagnetic switch function and continuity can be checked by connecting it as shown in Fig. 85. When the electromagnet leads are connected to the battery, the internal plunger should contact the switch terminals, creating continuity. Continuity should cease when the electromagnet leads are disconnected. An ohmmeter is shown in Fig. 85, though any self-powered continuity tester can be used for this purpose.

Overrunning Clutch:

Reduction gears and sprockets enable the starter motor to turn at much higher rpm than the engine in order to develop the necessary cranking force. When the engine starts to run, however, the starter motor must be quickly disengaged; otherwise the starter motor would be driven to excessive rpm by the engine, and the motor would become seriously damaged.

The overrunning clutch is a coupling mechanism that enables the starter motor to engage the engine's crankshaft or transmission shaft only while the starter motor is operating under a load (cranking the engine). When the engine starts, the engine's increased speed automatically disengages the starter motor.

Fig. 86 and 87 show cross sectional views of an overrunning clutch. The particular type illustrated is installed on the engine crankshaft and is chain driven, like the starter clutch used in Honda CB-360 and CB-500T motorcycles.

The starter motor drives the chain (1) and its sprocket (2) in the direction shown in Fig. 86 (some Honda models use a gear rather than a chain and sprocket). The clutch housing (4) is attached to the engine crankshaft (6) (some Honda models mount the clutch housing on a transmission shaft). Starter engagement is achieved by locking the sprocket to the clutch housing, and disengagement is achieved by unlocking these parts. Spring loaded rollers (5) in the clutch housing perform this locking/unlocking function.

The rollers (5) ride on ramps in the clutch housing (4). When extended, the rollers wedge the sprocket hub (3) tightly against the clutch housing. When the rollers are retracted, the sprocket hub and clutch housing are no longer locked together.

When the sprocket drives the clutch housing (i.e. starter motor cranks engine), the motion of the sprocket hub causes the rollers to extend and lock it to the clutch housing. When the clutch housing rotates at higher rpm than the sprocket (i.e. engine starts and its rpm increases), the relative motion of these parts retracts the rollers and disengages the starter motor.

Depending on the motorcycle model, lighting may be either A.C. (lighting current supplied by A.C. generator) or D.C. (lighting current supplied by battery). Battery powered D.C. lighting has the advantage of operating with undiminished intensity when the engine is idling or stopped. When hooking up or troubleshooting the lighting circuits, refer to the wiring diagrams shown in the owner's manual or shop manual.

Headlights:

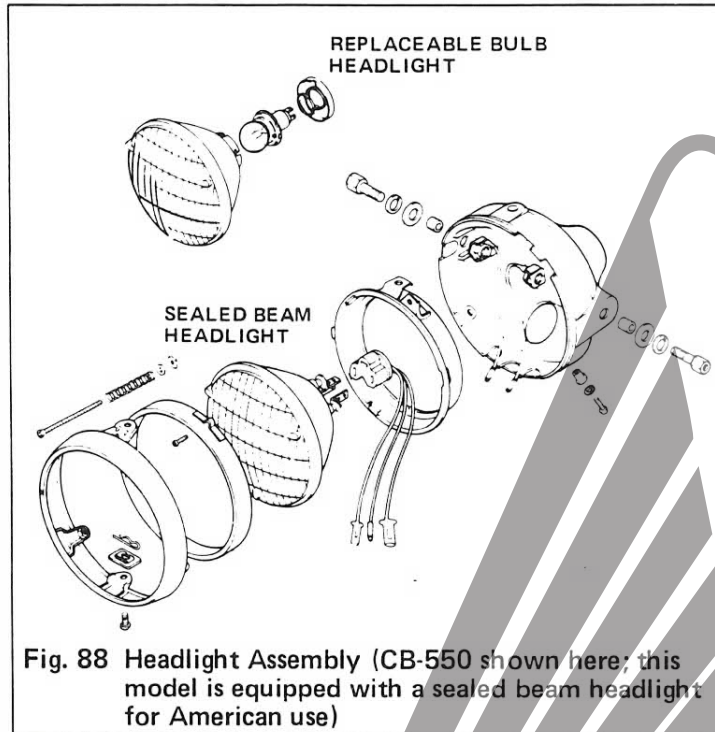

Fig. 88 Headlight Assembly (CB-550 shown here; this model is equipped with a sealed beam headlight for American use)

Headlights may have replaceable bulbs or may be sealed beam units (Fig. 88). A sealed beam headlight has the lens (3), reflector (4), and lighting filaments (6) assembled permanently in a sealed unit (Fig. 89). When a filament in a sealed beam headlight burns out, the entire unit must be replaced. It is somewhat more expensive to replace sealed beam units than bulbs, but the airtight seal excludes dust and moisture which could otherwise enter the headlight and tarnish or otherwise reduce the efficiency of the reflector.

There are two types of sealed beam construction. One type uses a glass reflector which is fused to the lens, forming its own protective bulb around the filaments. The other type uses a metal reflector permanently attached to the lens and sealed, but containing a conventional looking, non-removable bulb, as shown in Fig. 89.

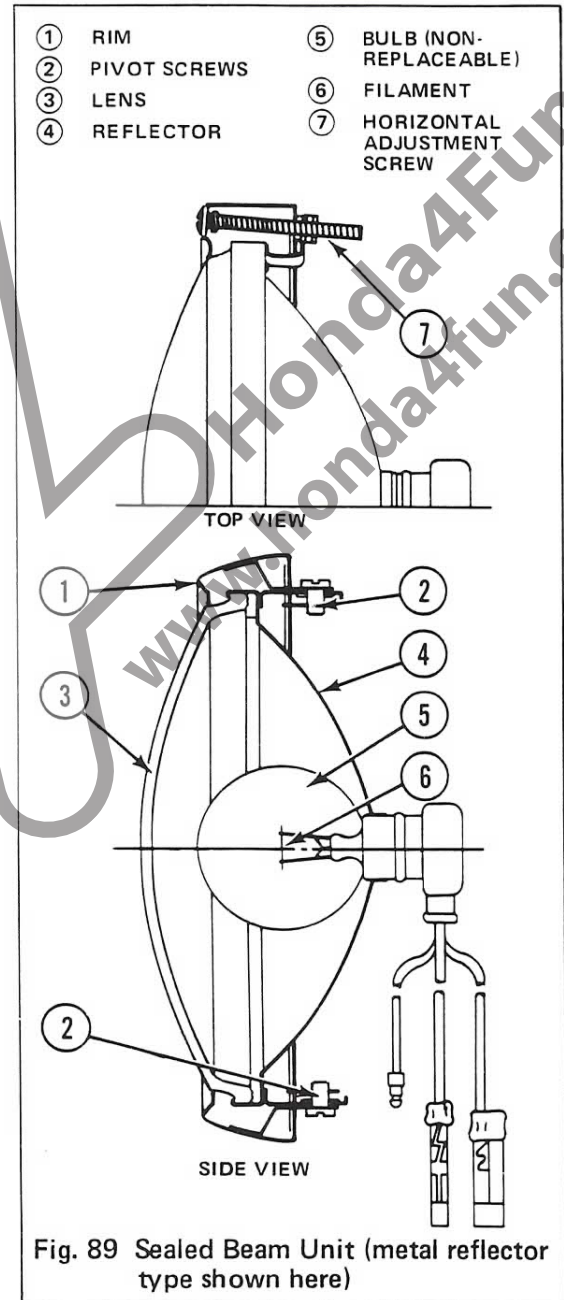

Fig. 89 Sealed Beam Unit (metal reflector type shown here)

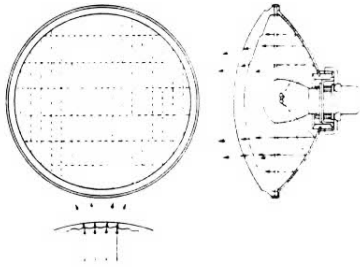

Fig. 90 Headlight Beam Reflection and Refraction

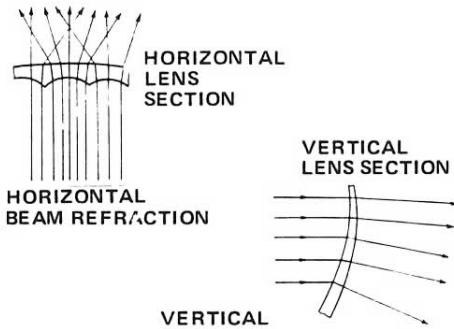

Fig. 91 Headlight Beam Refraction

- ① VERTICAL ADJUSTMENT (MOUNTING BOLTS)
- ② HORIZONTAL ADJUSTMENT SCREW

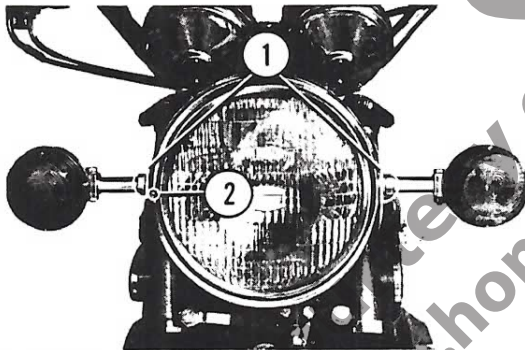

Fig. 92 Headlight Beam Adjustment

The inner surface of a headlight lens is composed of many light refracting segments. The edges of these segments are clearly visible from the outside and give the headlight its characteristic appearance, as though the lens were ruled off into rectangles (Fig. 90).

The shape of each lens segment is predominantly concave and causes light rays to diverge as they pass through the headlight lens (Fig. 91), providing broader illumination of the road ahead.

The headlight filaments emit light in all directions, and a reflector is required to redirect light rays toward the lens at a suitable angle (Fig. 90).

If a filament is moved off-center between the reflector and lens, the light rays it emits will strike the reflector and lens at a different angle. The direction and extent to which the filament is off-centered can therefore be used to alter the angle of the headlight beam. This principle is used to provide "high" and "low" beam capabilities within a single headlight unit. Dual beam headlights contain two filaments with just enough difference in position to provide high and low beam angles. A handlebar mounted switch enables the rider to light either high or low beam filaments.

Headlight mounting adjustments enable the beam to be precisely aimed. Vertical adjustment is accomplished by loosening the headlight mounting bolts ① (Fig. 92), and rotating the headlight assembly up or down. In some Honda models, such as the one shown in Fig. 92, the headlight mounting bolts are also the directional signal mounts. Horizontal adjustment is accomplished by turning an adjustment screw ② which pivots the headlight in its rim. Details of the horizontal adjustment mechanism are shown in Fig. 89.

Taillight and Stoplight:

The taillight on motorcycles intended for street use contains a two-filament bulb ① (Fig. 93). One filament is wired in parallel with the headlight. The other filament is connected to a switch that completes its circuit when the brakes are applied.

The red taillight lens ② has a clear section on its lower side to provide license plate illumination. Some off-road machines (e.g. Honda TL-250), which do not carry license plates may be equipped with a completely red taillight lens and may use a single filament bulb with no brake light circuit.

Stoplight Switches:

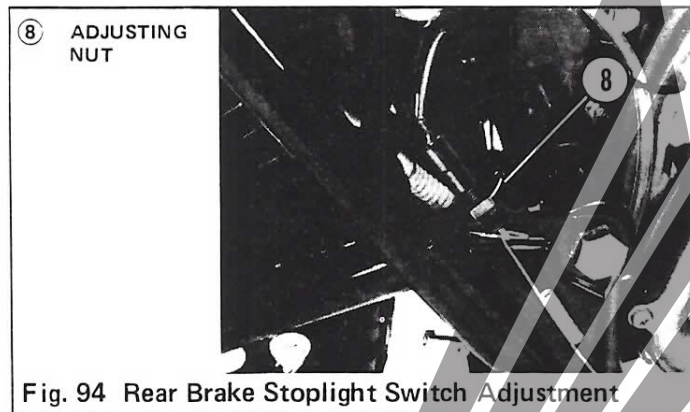

Fig. 94 Rear Brake Stoplight Switch Adjustment

All Honda motorcycles intended for street use are equipped with a rear brake stoplight switch of the type illustrated in Fig. 94 & 95. The rear brake pedal is connected to the operating rod ⑥ of the switch. When the pedal is depressed, this pulls the operating rod down, and the metal tip of the rod completes a circuit between the contacts ④, lighting the stoplight. When the brake pedal is released, an internal spring ⑦ retracts the operating rod, and its metal tip is withdrawn from contact, breaking the circuit.

An adjusting nut ⑧ mounts the switch to the motorcycle frame. The adjusting nut is turned to raise or lower the switch, controlling the distance the brake pedal must pull the operating rod before the stoplight comes on. Switch height should be adjusted so there is some brake pedal free travel, and the stoplight comes on just before the brake takes effect.

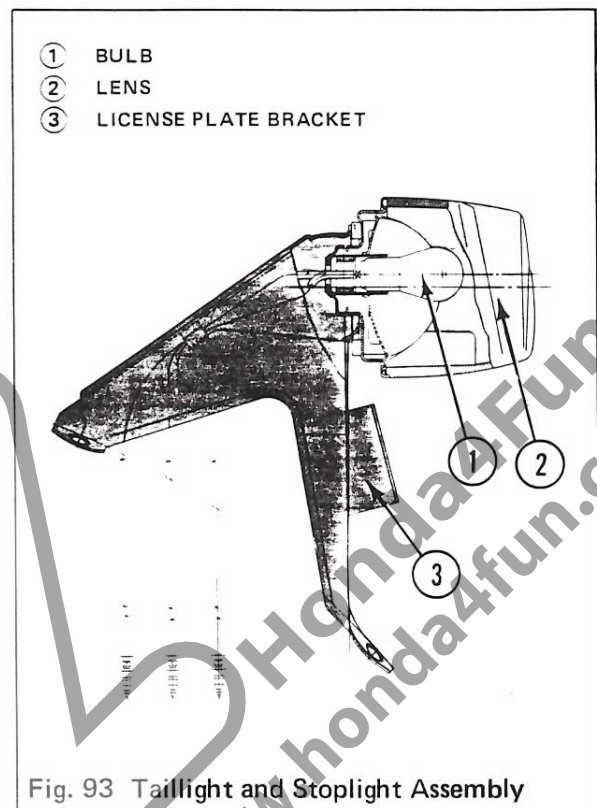

Fig. 93 Taillight and Stoplight Assembly

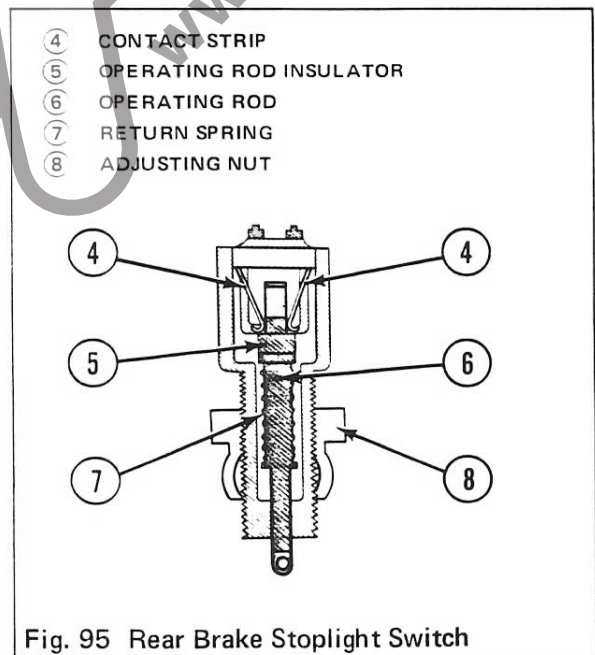

Fig. 95 Rear Brake Stoplight Switch

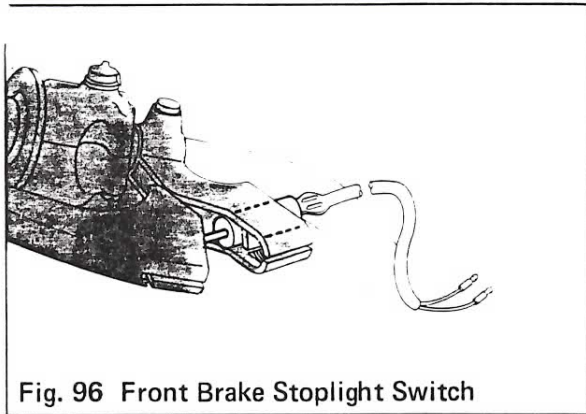

Fig. 96 Front Brake Stoplight Switch

Honda street motorcycles of recent manufacture will also have a *front* brake stoplight switch. The front brake switch and rear brake switch are wired in parallel with each other and in series with the stoplight, so application of either or both brakes will complete the stoplight circuit. One type of front brake switch uses a plunger which completes the stoplight circuit when released by the brake lever (Fig. 96). Some of the Honda models equipped with hydraulic front brakes use a switch which is activated by hydraulic pressure in the brake line. None of the *front* brake switches on Honda motorcycles are adjustable.

Turn Signal Lights:

A simple turn signal circuit is shown in Fig. 97. With main switch ④ and turn signal switch ② on, current flows from the battery ⑤, through a flasher unit ③, to either the left or right turn signal lights ①, as determined by the position of the turn signal switch ②. The flasher unit ③ repeatedly opens and closes the circuit, causing the turn signal lights to blink.

An indicator light, mounted in or near the instruments, flashes to show the rider that the turn signals are operating. A buzzer is sometimes added to the circuit to further attract the rider's attention, reminding him to cancel the signal after completing his turn. If a single indicator light is installed, it is wired in parallel with the turn signal switch ② and will operate when either left or right turn signals are used. If separate left and right indicator lights are installed, they must be wired in parallel with the turn signal lights ①.

An interior view of the flasher unit used in Honda motorcycles is shown in Fig. 98. The spring plate ⑨ can be likened to an archery bow, held near its center by the spring plate holder ⑦. The contact point strip ⑧ acts like a bowstring, pulling the edges of the spring plate downward. Current flowing through the contact point strip heats the strip, causing it to elongate, releasing tension on the spring plate. The ends of the spring plate then flip upward against a stop ⑪, raising the contact point strip and separating the contact points ⑩.

After current flow ceases, the contact point strip cools and contracts, and the spring plate again bows downward. This lowers the contact point strip, closing the contact points and completing the circuit. The cycle is

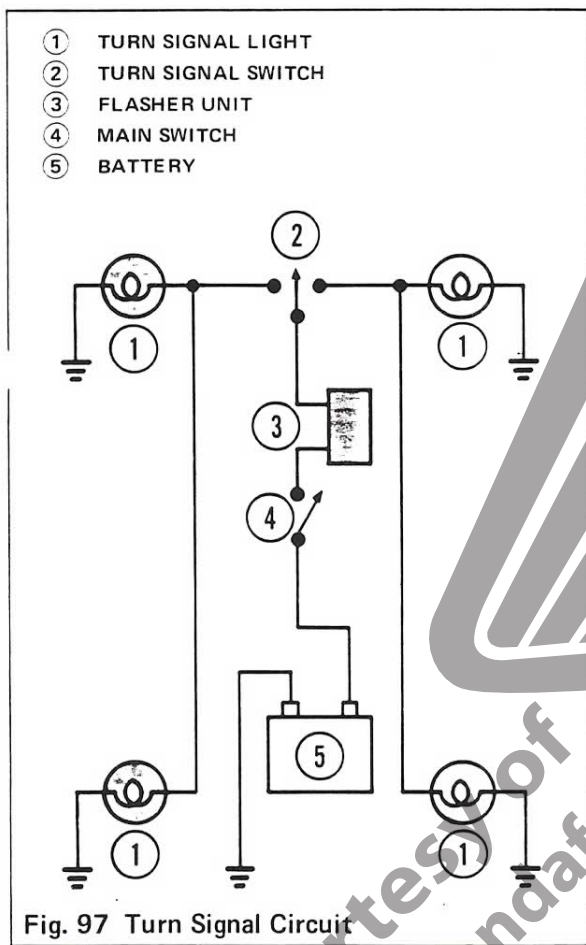

Fig. 97 Turn Signal Circuit

repeated, opening and closing the contact points at regular intervals.

Current flowing through the turn signal circuit must heat the contact point strip sufficiently to operate the spring plate. If one of the turn signal lights burns out or becomes disconnected, the remaining light may not draw enough amperage to develop the necessary heat and will remain lit, without blinking.

Horn:

The horn produces sound by vibrating a metal diaphragm. The frequency with which the diaphragm vibrates determines the pitch of the sound, and the extent of diaphragm movement determines the amplitude (loudness) of the sound.

In some horns, the sound waves generated by the diaphragm are channeled through a duct of increasing diameter which amplifies the sound. Other horns are not fitted with a duct, but have a resonator plate in front of the diaphragm. Both types are used in Honda motorcycles.

A cross sectional view of a typical motorcycle horn is shown in Fig. 99. When the main switch (2) is closed, and the horn button (14) is depressed, current flows from the battery (1), through contact points (3) & (4), and through an electromagnet (9). The electromagnet attracts an iron ring (8) on the diaphragm shaft (10), and the diaphragm (7) is pulled inward. When this occurs, the iron ring strikes an insulator (5) on the movable contact point (4), separating it from the fixed contact point (3), and the circuit is broken. A return spring (11) then moves the diaphragm shaft and diaphragm forward. This releases the movable contact point, the contact points close, and the cycle repeats itself as long as the horn button is depressed.

The horn is usually equipped with an adjustment screw (12) which controls the height of the contact point holder (13) in relation to the position of the iron ring on the diaphragm shaft. Adjustment is made by ear, to produce the best sound.

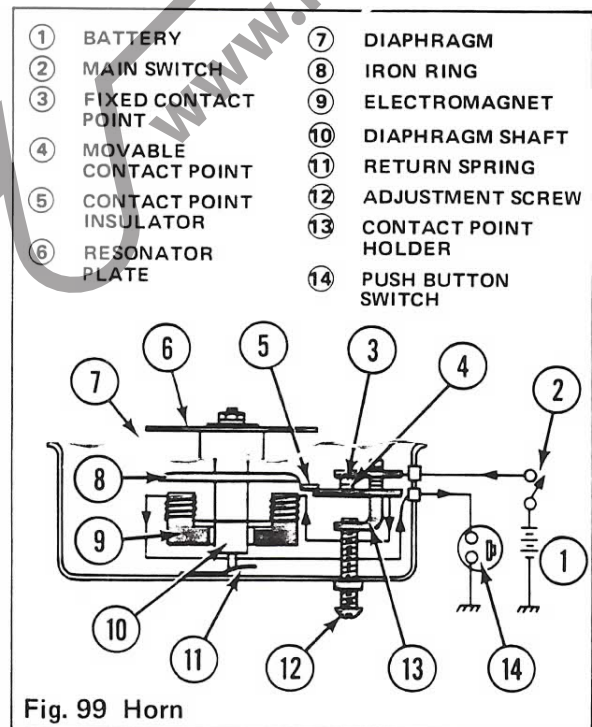
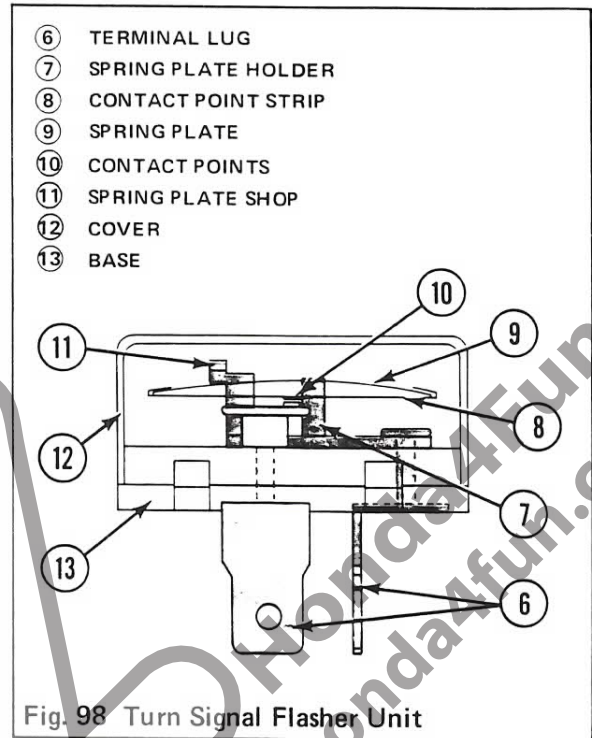

FUEL LEVEL AND COOLANT TEMPERATURE GAUGES/COOLING FAN

- ① BATTERY
- ② MAIN SWITCH
- ③ VOLTAGE REGULATOR
- ④ COOLANT TEMPERATURE METER
- ⑤ COOLANT TEMPERATURE SENSOR
- ⑥ FUEL LEVEL METER
- ⑦ FUEL LEVEL SENSOR
- ⑧ FLOAT

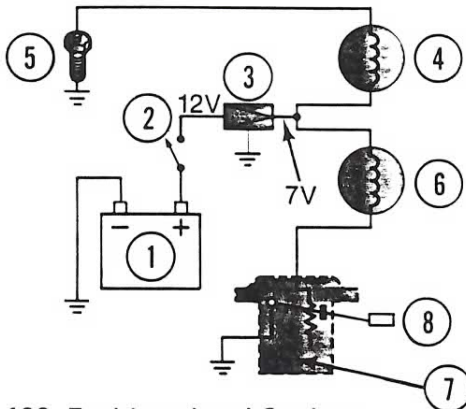

Fig. 100 Fuel Level and Coolant Temperature Gauge Circuits

- ① BATTERY
- ② MAIN SWITCH
- ③ FAN MOTOR
- ④ THERMOSTATIC SWITCH

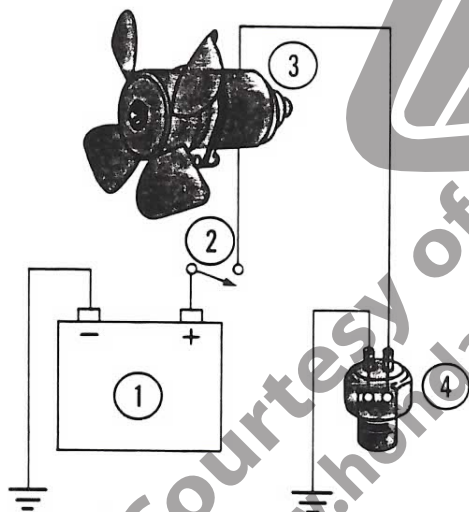

Fig. 101 Cooling Fan Circuit

Fuel Level and Coolant Temperature Gauges:

A diagram of the Honda GL-1000 fuel level and coolant temperature gauge circuit is shown in Fig. 100. The sensors and gauges require a 7 volt power supply. Since the Honda GL-1000 has a 12 volt battery, a voltage regulator (3) is used to reduce the voltage in this circuit to 7 volts.

The sensors (5) & (7) are variable resistance devices, controlling the amount of current flowing through the meters (4) & (6). The meter needles are electromagnetically controlled and respond by moving across a calibrated scale in proportion to the current flowing through their circuits. Lower resistance results in higher meter readings, and vice versa.

The fuel level sensor (7) is essentially a rheostat whose movable arm is attached to a float (8). As fuel level and float height become lower, current must travel through more of the sensor's resistor to complete its circuit. When the fuel tank is filled with gasoline, the float rises, and sensor resistance decreases.

The coolant temperature sensor (5) responds to heat. Resistance decreases as temperature rises.

Component testing procedures and resistance values are given in the shop manual.

Cooling Fan:

The Honda GL-1000 has an electrically driven fan behind the radiator. Fan operation is required only when the coolant (a 50-50 mixture of water and ethylene glycol anti-freeze) temperature exceeds the desired operating range. The fan motor (3) (Fig. 101) is therefore connected in series with a thermostatic switch (4). When coolant temperature reaches a threshold of 98° - 102°C (208° - 215°F), the thermostatic switch closes, and the fan will operate until coolant temperature is lowered enough to open the thermostatic switch, or until the main switch (2) is turned off manually.

Thermostatic switch operation can be tested by checking electrical continuity while the sensor end of the switch is immersed in heated liquid. The test procedure is explained in detail in the shop manual.

- A.C. generator (alternator)** (⊂): A device for converting mechanical energy into electrical energy of alternating current flow.
- A.C. generator rotor:** A magnet assembly that is rotated to induce electrical current in the stator.
- A.C. generator stator:** Nonrotating windings in which the A.C. generator rotor induces electrical current.
- alternating current (A.C.):** A flow of electricity which continuously reverses direction through repeated cycles.
- ammeter:** An instrument for measuring amperage.
- ampere (A.):** A unit of measurement of the flow rate of electricity. *Amperes* = volts ÷ ohms.
- ampere-hour (amp.-hr.):** A unit of measurement used mostly to rate the electrical energy a battery can deliver. *Ampere-hours* = amperes x flow time in hours.
- ampere-hour capacity:** The amount of electrical energy (expressed in ampere-hours) that a battery can deliver for a specified length of time.
- armature:** The moving component of an electric motor or other electromechanical device.
- battery** (⊂): A D.C. voltage source which converts chemical energy into electrical energy.
- chassis ground** (⊂, ⊂): A connection to the motorcycle frame, used to complete an electrical circuit.
- capacitor (condenser)** (→): A device containing two separated conducting surfaces which temporarily store electrical energy.
- commutator:** The part of an electric motor's armature to which the field coils are connected.
- detonation:** Explosive combustion of the air-fuel mixture in the combustion chamber occurring after the timed spark.
- direct current (D.C.):** A flow of electricity continuously in one direction.
- dwel angle:** The distance (measured in degrees or in percent of one full revolution) which the contact point cam of an ignition system rotates while the contact points remain closed.
- electrolyte:** A current carrying substance (e.g. battery acid) in which the conduction of electricity is accompanied by chemical action.
- electron:** A negatively charged particle orbiting the nucleus of an atom.
- energy transfer system:** A low tension magneto ignition system in which the contact points are connected in parallel with the magneto and ignition coil windings.
- field coil:** A coil of wire wound around an iron core, used in electric motors and in some A.C. generators to produce a magnetic field.
- fuse** (⊂): A protective device, usually a small wire or metal strip, which melts and breaks the circuit if current exceeds its rated value.
- ignition coil** (⊂ || ⊂): An iron core transformer which converts low voltage to high voltage for an ignition spark.
- induction:** Generation of electrical current in a conductor by variation of a magnetic field affecting the conductor.
- magneto:** An A.C. generator which serves as the voltage source for ignition.
- ohm** (Ω): A unit of measurement of the resistance to a flow of electricity. *Ohms* = volts ÷ amperes.
- Ohm's law:** The relationship between electromotive force (voltage), flow rate (amperage), and resistance (ohms). Volts = amperes x ohms.

GLOSSARY

ohmmeter: An instrument for measuring electrical resistance, calibrated in ohms.

parallel circuit: The interconnection of two or more electrical components such that current may flow from the voltage source directly to each component, without passing through any intervening component to complete the circuit.

rectifier: A device which converts alternating current into direct current.

resistance: The ability of a conductor to impede the flow of electricity, dissipating electrical energy in the form of heat. Resistance is measured in terms of ohms.

resistor (\sim): A device which can be connected into an electrical circuit for the purpose of impeding the flow of electricity to a specified degree.

rheostat: A variable resistor having one fixed terminal and one movable contact. A *rheostat* is adjustable to produce a range of resistance values.

series circuit: The interconnection of two or more electrical components such that current flowing from the voltage source must pass through each component in turn to complete the circuit.

series-parallel circuit: The interconnection of electrical components which branches into both series and parallel current paths.

silicon diode (\rightarrow): A two-electrode semiconductor which blocks current flow in only one direction.

spark plug heat range: The ability of a spark plug to transfer heat from its center electrode to its outer shell. Spark plugs are manufactured with a variety of heat transference rates for different engine temperature conditions.

spark plug reach: The distance from the shoulder above the spark plug threads to the opposite end of the threads.

volt (V.): A unit of measurement of the electromotive force which causes a flow of electricity. $Volts = amperes \times ohms$.

voltage regulator: A device which limits its output voltage to a predetermined value or which varies voltage according to a predetermined plan.

voltmeter: An instrument for measuring voltage.

VOM: Volt-ohm-milliammeter; a test instrument for measuring voltage, resistance, and amperes, with several calibration ranges.

watt (W.): A unit of measurement of electrical power. $Watts = volts \times amperes$.

zener diode (\rightarrow): An electronic device that blocks reverse current flow below a predetermined level and passes the amount of reverse current which exceeds that level.

ELECTRICAL SYSTEM TROUBLESHOOTING

PROBLEM	POSSIBLE CAUSE	CORRECTION
STARTER MOTOR FAILS TO OPERATE	<p>Discharged battery.</p> <p>Faulty starter motor, electromagnetic switch, or switch circuit.</p>	<p>Determine battery's state of charge. Recharge or replace battery, as necessary.</p> <p>With battery well charged, bypass the electromagnetic switch by short circuiting the switch terminals.</p> <p>If starter motor still does not operate, the problem is in the starter motor. Check brushes and commutator. Repair or replace starter motor, as necessary.</p> <p>If starter motor does operate, the problem is in the switch or switch circuit. Test switch and check circuit continuity.</p>
ENGINE FAILS TO START (other than electric starter problems).	<p>Fuel system problem.</p> <p>Discharged battery (battery ignition systems only).</p> <p>Fouled, worn, or damaged spark plugs.</p> <p>Faulty ignition contact points and/or incorrect ignition timing.</p> <p>Ignition system has open circuit or short circuit.</p>	<p>Check to be certain that there is fuel in the fuel tank and that fuel flows freely to the carburetor. If the engine has become flooded, clear the combustion chamber by cranking the engine several times with the throttle and choke open.</p> <p>Determine battery's state of charge. Recharge or replace battery, as necessary (if battery is not completely discharged, it may be possible to start the motorcycle using the kickstarter rather than the electric starter).</p> <p>Remove and inspect spark plugs. Replace if fouled, worn, or damaged. Select correct heat range for your operating conditions. Check electrode gap.</p> <p>Ignition system can be tested by cranking the engine with the spark plug lead connected to the spark plug, and the spark plug grounded against the exterior of the engine. The plug should produce a visible spark, if the ignition system is functioning.</p> <p>Inspect ignition contact points, Replace if worn, burned, or pitted (also replace capacitor if points appear abnormally burned or pitted). Adjust gap or dwell and ignition timing.</p> <p>Check electrical continuity of applicable wiring and switches. Repair or replace, as necessary.</p>

ELECTRICAL SYSTEM TROUBLESHOOTING

PROBLEM	POSSIBLE CAUSE	CORRECTION
<p>ENGINE FAILS TO START (other than electric starter problems).</p> <p>(continued from page 61)</p>	<p>Faulty magneto (magneto ignition systems only).</p> <p>Faulty ignition coil.</p> <p>No cylinder compression, or very low compression.</p>	<p>Isolate magneto coil from other circuit components, and check electrical continuity of coil windings. Replace magneto coil if it has an open circuit. Refer to shop manual for wiring diagram or special instructions.</p> <p>Disconnect ignition coil and check electrical continuity of primary and secondary coil windings (refer to shop manual to determine whether primary and secondary windings are separated or connected in your model). Replace ignition coil if there is an open circuit.</p> <p>Test ignition coil performance if test equipment is available (refer to shop manual) or obtain dealer assistance.</p> <p>Repair engine.</p>
<p>HARD STARTING, POOR IDLE</p>	<p>Fouled, worn, or damaged spark plugs.</p> <p>Faulty ignition contact points and/or incorrect ignition timing.</p> <p>Faulty magneto (magneto ignition systems only).</p> <p>Faulty ignition coil.</p> <p>Faulty or mis-adjusted carburetors.</p> <p>Low cylinder compression (may cause hard starting, poor idle, and loss of power).</p>	<p>See correction listed under ENGINE FAILS TO START.</p> <p>Repair, clean, and adjust, as necessary.</p> <p>Repair engine.</p>

ELECTRICAL SYSTEM TROUBLESHOOTING

PROBLEM	POSSIBLE CAUSE	CORRECTION
ENGINE BACKFIRES.	<p>Incorrect ignition timing.</p> <p>Incorrect air-fuel mixture ratio.</p>	<p>Adjust ignition timing.</p> <p>Adjust carburetors.</p>
<p>SPARK PLUGS SHOW SIGNS OF OVER-HEATING.</p> <p>ENGINE OVERHEATS.</p> <p>PISTON SEIZURE.</p>	<p>Excessively advanced ignition timing.</p> <p>Carburetor mixture too lean.</p> <p>Detonation.</p> <p>Preignition.</p> <p>Incorrect spark plug heat range (plug is too hot).</p> <p>Loss of engine oil, loss of coolant (liquid cooled engines), restricted air flow.</p>	<p>Adjust ignition timing</p> <p>Adjust, repair, or change jets, as necessary.</p> <p>Follow fuel octane recommendations for your model. Avoid lugging the engine.</p> <p>Determine and correct cause of hot spots in combustion chamber (e.g. carbon deposits, incorrect spark plug heat range).</p> <p>Install correct spark plug heat range.</p> <p>Repair as necessary.</p>
SPARK PLUGS FOUL.	<p>Excessive use of choke.</p> <p>Excessive idling and low rpm use.</p> <p>Carburetor mixture too rich.</p> <p>Incorrect spark plug heat range (plug is too cold).</p>	<p>Open choke as soon as engine warms up.</p> <p>Avoid excessive idling time. Run at normal rpm in gear.</p> <p>Adjust, repair, or change jets, as necessary.</p> <p>Install correct spark plug heat range.</p>

ELECTRICAL SYSTEM TROUBLESHOOTING

PROBLEM	POSSIBLE CAUSE	CORRECTION
<p>SPARK PLUGS FOUL.</p> <p>(continued from page 63).</p>	<p>Insufficient firing voltage.</p> <p>Excessive oil in combustion chamber.</p>	<p>Check ignition system components. Adjust or replace, as necessary.</p> <p>TWO-STROKE ENGINES: Use correct oil-fuel mixture.</p> <p>FOUR-STROKE ENGINES: Replace worn valve guides, worn piston rings, or damaged pistons.</p>
<p>BATTERY DOES NOT BECOME FULLY CHARGED, OR IS PERSISTENTLY DISCHARGED.</p>	<p>Infrequent motorcycle use, low rpm operation, excessive use of electric starter.</p> <p>Low battery electrolyte level.</p> <p>Faulty battery.</p> <p>Open circuit in charging system, poor contact at battery terminals, or short circuits anywhere on the motorcycle.</p> <p>Faulty generator, rectifier, or voltage regulator.</p>	<p>If motorcycle usage precludes normal charging, the battery must be periodically removed and connected to a battery charger.</p> <p>Check electrolyte level, and add water as necessary.</p> <p>Remove battery from motorcycle and connect to a battery charger. Check battery voltage and specific gravity after charging. Replace battery if it cannot be fully charged or will not retain a charge.</p> <p>Check circuit continuity. Repair open or short circuit. Clean battery terminals and cables, and connect securely.</p> <p>Refer to shop manual for wiring diagram, testing procedure, and specifications.</p>
<p>BATTERY BECOMES OVERCHARGED.</p> <p>EXCESSIVE WATER LOSS FROM ELECTROLYTE.</p>	<p>Faulty voltage regulator.</p>	<p>Replace voltage regulator.</p>

Courtesy of
www.hondafour.com



Honda4Fun
www.honda4fun.com